

Model K-P3
China Model
(Machine Code: G091)

SERVICE MANUAL

12 November, 2003
Subject to change

Trademarks

Microsoft®, Windows®, and MS-DOS® are registered trademarks of Microsoft Corporation in the United States and /or other countries.

PostScript® is a registered trademark of Adobe Systems, Incorporated.

PCL® is a registered trademark of Hewlett-Packard Company.

Ethernet® is a registered trademark of Xerox Corporation.

PowerPC® is a registered trademark of International Business Machines Corporation.

Other product names used herein are for identification purposes only and may be trademarks of their respective companies. We disclaim any and all rights involved with those marks.

IMPORTANT SAFETY NOTICES

PREVENTION OF PHYSICAL INJURY

1. Before disassembling or assembling parts of the printer and peripherals, make sure that the printer power cord is unplugged.
2. The wall outlet should be near the printer and easily accessible.
3. Note that some components of the printer and the paper tray unit are supplied with electrical voltage even if the main power switch is turned off.
4. If any adjustment or operation check has to be made with exterior covers off or open while the main switch is turned on, keep hands away from electrified or mechanically driven components.
5. The inside and the metal parts of the fusing unit become extremely hot while the printer is operating. Be careful to avoid touching those components with your bare hands.

HEALTH SAFETY CONDITIONS

Toner and developer are non-toxic, but if you get either of them in your eyes by accident, it may cause temporary eye discomfort. Try to remove with eye drops or flush with water as first aid. If unsuccessful, get medical attention.

OBSERVANCE OF ELECTRICAL SAFETY STANDARDS

1. The printer and its peripherals must be installed and maintained by a customer service representative who has completed the training course on those models.
2. The NVRAM on the system control board has a lithium battery which can explode if replaced incorrectly. Replace the NVRAM only with an identical one. The manufacturer recommends replacing the entire NVRAM. Do not recharge or burn this battery. Used NVRAM must be handled in accordance with local regulations.

SAFETY AND ECOLOGICAL NOTES FOR DISPOSAL

1. Do not incinerate toner bottles or used toner. Toner dust may ignite suddenly when exposed to an open flame.
2. Dispose of used toner, developer, and organic photoconductors in accordance with local regulations. (These are non-toxic supplies.)
3. Dispose of replaced parts in accordance with local regulations.
4. When keeping used lithium batteries in order to dispose of them later, do not put more than 100 batteries per sealed box. Storing larger numbers or not sealing them apart may lead to chemical reactions and heat build-up.

LASER SAFETY

The Center for Devices and Radiological Health (CDRH) prohibits the repair of laser-based optical units in the field. The optical housing unit can only be repaired in a factory or at a location with the requisite equipment. The laser subsystem is replaceable in the field by a qualified Customer Engineer. The laser chassis is not repairable in the field. Customer engineers are therefore directed to return all chassis and laser subsystems to the factory or service depot when replacement of the optical subsystem is required.

⚠ WARNING
Use of controls, or adjustment, or performance of procedures other than those specified in this manual may result in hazardous radiation exposure.

⚠ WARNING
WARNING: Turn off the main switch before attempting any of the procedures in the Laser Unit section. Laser beams can seriously damage your eyes.

Caution Labels



LASER-3.WMF

CAUTION VORSICHT >PS<	<table border="1"> <tr> <td> INVISIBLE LASER RADIATION WHEN OPEN. AVOID EXPOSURE TO BEAM. UNSICHTBARE LASERSTRAHLUNG WENN ABDECKUNG GEÖFFNET. NICHT DEM STRAHL AUSSETZEN. </td> </tr> </table>	INVISIBLE LASER RADIATION WHEN OPEN. AVOID EXPOSURE TO BEAM. UNSICHTBARE LASERSTRAHLUNG WENN ABDECKUNG GEÖFFNET. NICHT DEM STRAHL AUSSETZEN.
INVISIBLE LASER RADIATION WHEN OPEN. AVOID EXPOSURE TO BEAM. UNSICHTBARE LASERSTRAHLUNG WENN ABDECKUNG GEÖFFNET. NICHT DEM STRAHL AUSSETZEN.		

G065RLV.WMF

 DANGER	INVISIBLE LASER RADIATION WHEN OPEN. AVOID DIRECT EXPOSURE TO BEAM.
>PS<	

LASER-1.WMF

Lithium Batteries (Memory Back-up)

CAUTION







The danger of explosion exists if a battery of this type is incorrectly replaced. Replace only with the same or an equivalent type recommended by the manufacturer. Discard used batteries in accordance with the manufacturer's instructions.

Warning Concerning Copyright

Many documents are copyrighted. Such documents may not be reproduced by copying or in any other form without the express permission of the copyright holder.

Conventions in this Manual

This manual uses several symbols and some simple abbreviations.

Symbol	What it means
	Refer to section number
	See Core Tech Manual for details
	Screw
	Connector
	E-ring
	C-ring
HP	Home Position
T/S	Transfer/Separation

The following notations are used in text to describe the direction of paper feed: lengthwise and sideways. The annotations "SEF" and "LEF" denote "Short Edge Feed" and "Long Edge Feed". (The arrows indicate the direction of paper feed.)

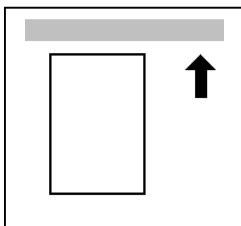

Lengthwise (SEF)

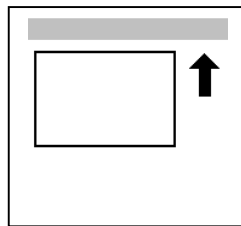

Sideways (LEF)

TABLE OF CONTENTS

1. INSTALLATION.....	1-1
1.1 INSTALLATION REQUIREMENTS.....	1-1
1.1.1 ENVIRONMENT	1-1
1.1.2 MACHINE LEVEL	1-1
1.1.3 MACHINE SPACE REQUIREMENT	1-1
1.1.4 POWER SUPPLY	1-2
1.2 MACHINE INSTALLATION.....	1-2
1.2.1 MAIN UNIT.....	1-2
1.2.2 HARDWARE OPTIONS.....	1-2
1.2.3 MEMORY OPTIONS.....	1-2
1.2.4 DRIVERS AND SOFTWARE	1-2
1.2.5 FIRMWARE UPGRADE.....	1-3
1.3 SUPPLIES	1-3
2. PREVENTIVE MAINTENANCE SCHEDULE.....	2-1
2.1 USER MAINTENANCE.....	2-1
2.2 SERVICE MAINTENANCE	2-2
3. REPLACEMENT AND ADJUSTMENT	3-1
3.1 GENERAL.....	3-1
3.1.1 PRECAUTIONS ON DISASSEMBLY	3-1
3.1.2 RELEASING PLASTIC LATCHES.....	3-3
3.1.3 AFTER SERVICING THE MACHINE.....	3-3
3.2 SPECIAL TOOLS.....	3-3
3.3 COVERS.....	3-4
3.3.1 FRONT COVER.....	3-4
3.3.2 UPPER COVER.....	3-4
3.3.3 BY-PASS TRAY UNIT	3-5
3.3.4 EXTERIOR COVERS	3-5
3.4 LASER UNIT.....	3-6
3.4.1 CAUTION DECAL LOCATIONS	3-6
3.4.2 POLYGON MIRROR MOTOR	3-7
3.4.3 LASER SYNCHRONIZATION DETECTOR.....	3-7
3.4.4 LASER UNIT.....	3-8
3.4.5 LASER DIODE UNIT	3-9
3.4.6 LASER BEAM PITCH ADJUSTMENT	3-10
3.5 TRANSFER ROLLER.....	3-11
3.6 TONER END SENSOR.....	3-11
3.7 FUSING	3-12
3.7.1 FUSING UNIT	3-12
3.7.2 HOT ROLLER AND FUSING LAMP	3-13
3.7.3 PRESSURE ROLLER.....	3-15
3.7.4 THERMISTOR AND THERMOSTAT	3-16
3.7.5 HOT ROLLER STRIPPERS.....	3-17

3.8	PAPER FEED	3-18
3.8.1	PAPER FEED ROLLER.....	3-18
3.8.2	FRICTION PAD.....	3-18
3.9	BY-PASS TRAY.....	3-19
3.9.1	BY-PASS TRAY UNIT AND BY-PASS FEED ROLLER.....	3-19
3.10	PRINTER CONTROLLER BOARD.....	3-20
3.11	ENGINE BOARD	3-21
3.12	MAIN MOTOR	3-22
3.13	SOLENOIDS AND CLUTCHES	3-22
3.14	POWER SUPPLY BOARD AND HIGH VOLTAGE SUPPLY BOARD ..	3-23
3.15	COOLING FAN.....	3-24
3.16	IMAGE ADJUSTMENT	3-25
3.16.1	REGISTRATION ADJUSTMENT	3-25
3.16.2	PARALLELOGRAM IMAGE ADJUSTMENT.....	3-25
4.	TROUBLESHOOTING.....	4-1
4.1	SERVICE CALL CONDITIONS.....	4-1
4.1.1	SUMMARY.....	4-1
4.1.2	SC CODE DESCRIPTIONS.....	4-2
4.2	CONTROLLER ERROR	4-5
4.3	ELECTRICAL COMPONENT DEFECTS.....	4-7
4.3.1	SENSORS	4-7
4.3.2	SWITCHES.....	4-7
4.4	BLOWN FUSE CONDITIONS.....	4-8
4.5	LEDS	4-8
5.	SERVICE TABLES.....	5-1
5.1	SERVICE PROGRAM MODE.....	5-1
5.1.1	ENABLING AND DISABLING SERVICE PROGRAM MODE	5-1
	Entering the Service Mode.....	5-1
	Inputting a Value or Setting for a Service Program	5-1
	Exiting Service Mode	5-1
5.2	PRINTER CONTROLLER SERVICE MODE	5-2
5.2.1	SERVICE MODE MENU (“1. SERVICE MENU”).....	5-2
5.2.2	BIT SWITCH PROGRAMMING	5-2
5.3	PRINTER ENGINE SERVICE MODE	5-3
5.3.1	SERVICE MODE TABLE	5-3
	SP1-xxx: Feed.....	5-3
	SP2-xxx: Drum	5-5
	SP3-xxx: Process.....	5-6
	SP5-xxx: Mode.....	5-7
	SP7-xxx: Data Log	5-14
	SP8-xxx: Counters	5-15
5.4	UPDATING THE FIRMWARE.....	5-20
5.4.1	CONTROLLER FIRMWARE	5-20
5.4.2	ENGINE FIRMWARE.....	5-21

5.4.3 ERROR RECOVERY	5-22
Controller.....	5-22
Engine	5-22
5.5 REMOTE FIRMWARE UPDATE (RFU).....	5-23
5.6 LOOP-BACK TEST	5-23
5.7 POWER-ON SELF TESTS	5-23
5.8 USER PROGRAM MODES	5-24
User Mode Tree	5-24
5.9 DIP SWITCHES.....	5-25
Controller Board	5-25
6. DETAILED SECTION DESCRIPTIONS.....	6-1
6.1 OVERVIEW	6-1
6.1.1 MECHANICAL COMPONENT LAYOUT	6-1
6.1.2 PAPER PATH	6-2
6.2 BOARD STRUCTURE	6-3
6.2.1 BLOCK DIAGRAM	6-3
6.2.2 DESCRIPTIONS	6-4
6.2.3 CONTROLLER BOARD.....	6-5
6.3 PRINTING PROCESS	6-6
6.3.1 OVERVIEW.....	6-6
6.3.2 LASER EXPOSURE	6-7
Overview	6-7
Automatic Power Control (APC).....	6-8
LD Safety Mechanisms	6-9
6.3.3 CARTRIDGE OVERVIEW.....	6-10
6.3.4 DRUM CHARGE	6-10
6.3.5 DEVELOPMENT	6-11
Toner Supply.....	6-11
Development Unit.....	6-11
Toner Density Control	6-12
Development Bias	6-12
Toner End Detection	6-13
6.3.6 IMAGE TRANSFER AND PAPER SEPARATION	6-14
Overview	6-14
Transfer Roller Cleaning	6-15
6.3.7 CLEANING.....	6-15
6.3.8 QUENCHING	6-16
6.3.9 ID CHIP AND INTERNAL THERMISTOR.....	6-16
6.4 PAPER FEED	6-17
6.4.1 OVERVIEW.....	6-17
Paper Tray	6-17
By-pass Tray.....	6-17
6.4.2 PAPER TRAY	6-18
Tray Extension	6-18
Paper Sizes.....	6-18
Paper Lift.....	6-18
Paper Feed and Registration	6-19
Paper Size Detection	6-20

Paper Size Detection	6-20
Paper End Detection	6-21
Remaining Paper Detection	6-22
6.4.3 BY-PASS TRAY	6-23
6.5 IMAGE FUSING AND PAPER EXIT	6-24
6.5.1 OVERVIEW.....	6-24
6.5.2 FUSING DRIVE	6-25
6.5.3 FUSING ENTRANCE AND GUIDE SHAFT	6-25
6.5.4 PRESSURE ROLLER.....	6-26
6.5.5 NEW FUSING UNIT DETECTION.....	6-27
6.5.6 FUSING TEMPERATURE CONTROL.....	6-28
Overheat Protection	6-29
6.5.7 PAPER EXIT.....	6-29
6.5.8 ENERGY SAVER MODE.....	6-30
Entering Energy Saver Mode.....	6-30
Leaving Energy Saver Mode.....	6-30
6.6 CONTROLLER FUNCTIONS	6-31
6.6.1 METER CHARGE MODE	6-31
Meter-charge Counter Display	6-31
PM Warning Display.....	6-31

PERIPHERALS

DUPLEX UNIT (G552)

1. REPLACEMENT AND ADJUSTMENT	G552-1
1.1 EXTERIOR COVERS	G552-1
1.2 DUPLEX BOARD AND SENSORS.....	G552-2
2. DETAILED DESCRIPTION.....	G552-3
2.1 OVERALL MACHINE INFORMATION.....	G552-3
2.1.1 MECHANICAL COMPONENT LAYOUT	G552-3
2.1.2 DRIVE LAYOUT.....	G552-4
2.1.3 ELECTRICAL COMPONENT LAYOUT	G552-4
2.2 DETAILED SECTION DESCRIPTIONS.....	G552-5
2.2.1 BASIC OPERATION	G552-5
Longer than A4 LEF/LT LEF	G552-5
Length up to A4 LEF/LT LEF.....	G552-6
2.2.2 FEED IN AND EXIT MECHANISM	G552-7
Feeding paper into the duplex unit:.....	G552-7
Inversion and exit:.....	G552-7

FOUR-BIN MAILBOX (G553)

1. REPLACEMENT AND ADJUSTMENT.....	G553-1
1.1 EXTERIOR COVERS	G553-1
1.2 OVERFLOW AND VERTICAL TRANSPORT SENSORS.....	G553-2
1.3 MAIN MOTOR	G553-3
2. DETAILED DESCRIPTIONS	G553-4
2.1 OVERALL MACHINE INFORMATION.....	G553-4
2.1.1 MECHANICAL COMPONENT LAYOUT	G553-4
2.1.2 DRIVE LAYOUT.....	G553-5
2.1.3 ELECTRICAL COMPONENT LAYOUT	G553-6
2.2 DETAILED SECTION DESCRIPTIONS.....	G553-7
2.2.1 BASIC OPERATION	G553-7

ONE-BIN SHIFT TRAY (G554)

1. REPLACEMENT AND ADJUSTMENT.....	G554-1
1.1 EXTERIOR COVERS	G554-1
1.2 SHIFT TIMING AND TRAY PAPER SENSORS	G554-2
1.3 COVER AND OVERFLOW SENSORS.....	G554-2
1.4 MAIN MOTOR	G554-3

2. DETAILED DESCRIPTIONS	G554-4
2.1 OVERALL MACHINE INFORMATION.....	G554-4
2.1.1 MECHANICAL COMPONENT LAYOUT	G554-4
2.1.2 DRIVE LAYOUT.....	G554-4
2.1.3 ELECTRICAL COMPONENT LAYOUT	G554-5
2.1.4 BASIC OPERATION	G554-6
2.1.5 SORT MODE OPERATION	G554-6

PAPER TRAY UNIT (G555)

1. REPLACEMENT AND ADJUSTMENT	G555-1
1.1 PAPER FEED UNIT.....	G555-1
1.2 PAPER FEED ROLLER.....	G555-2
1.3 FRICTION PAD	G555-2
2. DETAILED DESCRIPTIONS	G555-3
2.1 OVERALL MACHINE INFORMATION.....	G555-3
2.1.1 MECHANICAL COMPONENT LAYOUT	G555-3
2.1.2 ELECTRICAL COMPONENT LAYOUT	G555-3
2.2 DETAILED SECTION DESCRIPTIONS.....	G555-4
2.2.1 PAPER FEED AND SEPARATION.....	G555-4
2.2.2 PAPER LIFT	G555-5
2.2.3 PAPER END DETECTION.....	G555-5
2.2.4 REMAINING PAPER DETECTION.....	G555-6
2.2.5 PAPER SIZE DETECTION.....	G555-7

SPECIFICATIONS.....	SPEC-1
1. GENERAL SPECIFICATIONS.....	SPEC-1
2. PHYSICAL SPECIFICATIONS	SPEC-2
3. CONTROLLER	SPEC-3
4. SUPPORTED PAPER SIZES	SPEC-4
5. OPERATION PANEL LED SPECIFICATIONS	SPEC-5
6. EXTERNAL OPTIONS.....	SPEC-5
7. SOFTWARE ACCESSORIES.....	SPEC-6
7.1 PRINTER DRIVERS	SPEC-6
7.2 CD-ROM CONTENTS	SPEC-7
8. MACHINE CONFIGURATION	SPEC-8
8.1 SYSTEM COMPONENTS.....	SPEC-8
8.2 INTERNAL OPTIONS	SPEC-9

1. INSTALLATION

1.1 INSTALLATION REQUIREMENTS

The installation instructions in this section are for the G091 China model machine.

1.1.1 ENVIRONMENT

1. Temperature Range: 10 °C to 32 °C (50 °F to 89.6 °F)
2. Humidity Range: 15 % to 89 % RH
3. Ambient Illumination: Less than 2,000 lux (do not expose to direct sunlight).
4. Ventilation: 3 times/hr/person
5. Avoid areas that are exposed to sudden temperature changes. This includes:
 - 1) Areas directly exposed to cool air from an air conditioner.
 - 2) Areas directly exposed to heat from a heater.
6. Do not install this machine in an area where it will be exposed to corrosive gases.
7. Do not install the machine at locations over 2,500 m (8,125 ft.) above sea level.
8. Put the machine on a strong and level base. Inclination on any side should not exceed 5 mm.
9. Do not put the machine where it may be subjected to strong vibrations.

1.1.2 MACHINE LEVEL

Front to back: Within 5 mm. (0.2 inches) of level.

Right to left: Within 5 mm. (0.2 inches) of level.

1.1.3 MACHINE SPACE REQUIREMENT

Place the machine near the power source, providing the clearance as shown below:

- A: Over 10 cm (4 inches)
- B: Over 10 cm (4 inches)
- C: Over 100 cm (40 inches)
- D: Over 10 cm (4 inches)

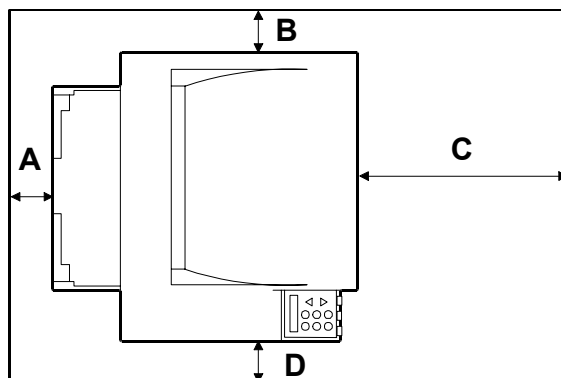

G094I500.WMF

1.1.4 POWER SUPPLY

⚠ CAUTION
<ol style="list-style-type: none"> 1. Make sure the plug is firmly inserted in the outlet. 2. Avoid multi-wiring. 3. Be sure to ground the machine.

	220-240 volts, 50 Hz/60Hz: More than 6 A
Permissible voltage	Fluctuation: $\pm 10\%$
Do not set anything on the power cord	

1.2 MACHINE INSTALLATION

Refer to the following sections of the Operating Instructions for installation details for all models.

1.2.1 MAIN UNIT

1. Installing the Printer Unit: Quick Installation Guide.
2. Connecting the machine to a computer: Quick Installation Guide.

1.2.2 HARDWARE OPTIONS

1. Installing the Paper Feed Unit: Section two of the Set-up Guide.
2. Installing the Duplex Unit: Section two of the Set-up Guide.
3. Installing the One-Bin Shift Tray. Section two of the Set-up Guide.
4. Installing the Four-Bin Mailbox. Section two of the Set-up Guide.

1.2.3 MEMORY OPTIONS

1. Installing the Memory Unit: Section two of the Set-up Guide.
2. Installing the Hard Disk: Section two of the Set-up Guide.

1.2.4 DRIVERS AND SOFTWARE

Refer to section 4 of the Set-up Guide for installation procedures.

1.2.5 FIRMWARE UPGRADE

Refer to section 5.4 of the Service Manual.

1.3 SUPPLIES

- Maintenance kit
- AIO

2. PREVENTIVE MAINTENANCE SCHEDULE

2.1 USER MAINTENANCE

The customer can do all PM items with the Maintenance Kit (G770).

Meter-charge mode must be set to “disabled” (engine SP mode 5930).

Cross-reference: Section 5.3 Engine service mode

The Operation panel shows “Replace Maintenance Kit” when the PM counter gets to 90K. After the user replaces the fusing unit in the maintenance kit, the machine automatically resets the PM counter.

Item	Quantity	Remarks
Fusing unit	1	
Transfer roller	1	
Paper feed roller	1	For standard tray
Paper feed roller	2	For optional tray(s)
Friction pad	1	For standard tray
Friction pad	2	For optional tray(s)

2.2 SERVICE MAINTENANCE

The table shows the PM items done by service.

- NOTE:** 1) To disable the user's PM warning set meter-charge mode on in printer engine service mode.
- 2) Make sure to reset the PM counters with engine SP mode 7-804 after you complete PM.
- 7-804-1: Transfer roller
 - 7-804-2: Paper feed roller
 - 7-804-3: Fusing unit.

Symbol key: C: Clean, R: Replace, L: Lubricate, I: Inspect

Main unit

Item	90K	EM	Quantity	Remarks
Paper Feed				
Paper Feed Roller	R	C	1	Clean with water
Friction Pad	R	C	1	Clean with water
Registration Roller	C	C	1	Clean with water
Bottom Plate Pad	C	C	1	Clean with water
Around the Drum				
Transfer Roller	R		1	
Fusing Unit and Paper Exit				
Hot Roller	R		1	
Pressure Roller	R		1	
Hot Roller Strippers	R		G091: 5 G094/095: 3	
Fusing Thermistor	R	C	1	Clean with alcohol if necessary.
Bushings - Hot Roller	R		2	
Bushings - Pressure Roller	R		2	
Fusing Entrance and Exit Guide Plates	C		1 each	Clean with water or alcohol

Paper Tray Unit

	90K	EM	Quantity	NOTE
Paper Feed Roller	R	C	1	Clean with water
Friction Pad	R	C	1	Dry cloth
Bottom Plate Pad	C	C	1	Clean with water

One-Bin Shift Tray

	90K	EM	Quantity	NOTE
Exit Rollers		C		Clean with water
Driven Rollers		C		Clean with water
Transport Rollers		C		Clean with water
Paper Tray		C		Clean with water
Tray Paper Sensor		C		Clean with water

Four-Bin Mailbox

	90K	EM	Quantity	NOTE
Exit Rollers		C		Clean with water
Driven Rollers		C		Clean with water
Trays		C		Clean with water

Preventive Maintenance

3. REPLACEMENT AND ADJUSTMENT

⚠ CAUTION

Turn off the main power switch and unplug the machine before attempting any of the procedures in this section.

The Replacement and Adjustment procedures in this section are for the G091 China model machine.

NOTE: This manual uses these symbols.

☛ : See or Refer to

🔩 : Screws

🔌 : Connector

3.1 GENERAL

3.1.1 PRECAUTIONS ON DISASSEMBLY

Use extreme caution when removing and replacing components. The cables in the machine are located very close to moving parts; proper routing is a must.

After components have been removed, any cables that have been displaced during the procedure must be restored as close as possible to their original positions.

Before removing any component from the machine, note any cable routings that may be affected.

Before servicing the machine:

1. Verify that documents are not stored in memory.
2. Remove the toner cartridge before you remove parts.
3. Unplug the power cord.
4. Work on a flat and clean surface.
5. Replace with authorized components only.
6. Do not force plastic material components.

Make sure all components are returned to their original positions.

Laser unit

1. Do not loosen or adjust the screws securing the LD drive board on the LD unit. Doing so will throw the LD unit out of adjustment.
2. Do not adjust the variable resistors on the LD unit, as these are permanently adjusted at the factory. If replacement of the LD drive board is necessary, replace the entire LD unit.
3. Keep the polygon mirror and toroidal lens free of dust. Laser performance is very sensitive to dust on these components.
4. Do not touch the shield glass or the surface of the polygon mirror with bare hands.
5. Do not adjust the Laser Synchronization detector on the LD unit, as these are permanently adjusted at the factory. If the position of the Laser Synchronization detector has changed from the factory set position, SC 322 will be shown.

Transfer Roller

1. Never touch the surface of the transfer roller with bare hands.
2. Be careful not to scratch the transfer roller, as the surface is easily damaged.

Fusing

1. After installing the fusing thermistor, make sure that it is in contact with the hot roller and that the roller can rotate freely.
2. Be careful to avoid damage to the hot roller stripper pawls and their tension springs.
3. Do not touch the fusing lamp and rollers with bare hands.
4. Make sure that the fusing lamp is positioned correctly and that it does not touch the inner surface of the hot roller.

Paper Feed

1. Do not touch the surface of paper feed rollers.
2. To avoid misfeeds, the side and end fences in each paper tray must be positioned correctly so as to align with loaded paper size.

3.1.2 RELEASING PLASTIC LATCHES

Many of the parts are held in place with plastic latches. The latches break easily, so release them carefully.

To remove such parts, press the hook end of the latch away from the part to which it is latched.

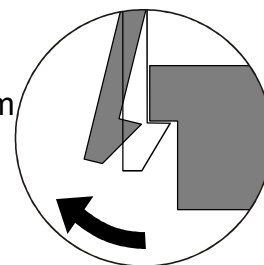

G094R513.WMF

3.1.3 AFTER SERVICING THE MACHINE

1. Make sure all parts that require grounding are properly grounded.
2. Make sure the interlock switch is functioning.
3. Do not leave unused solder or parts inside the machine.
4. Do not leave any tools inside the machine.
5. Make sure all wires are properly connected and routed.
6. Make sure wires are not jammed between parts of the machine.

 Replacement
Adjustment

3.2 SPECIAL TOOLS

Part Number	Description	Q'ty	Remarks
N8036701	Flash Memory Card - 4MB	1	Used in common with other printers.
N8031000	Card Case	1	Used in common with other printers.
A0069104	Scanner Positioning Pin (4 pieces/set)	1	Used for LD Unit positioning. Used in common with the model K-P series and other models.
	Ricoh System Information tool (Support Tool Version 2)		Released March 31, 2003
	Basic version	1	
	Mail version	1	

3.3 COVERS

3.3.1 FRONT COVER

To open the front cover, gently push the cover inward (2 hooks).

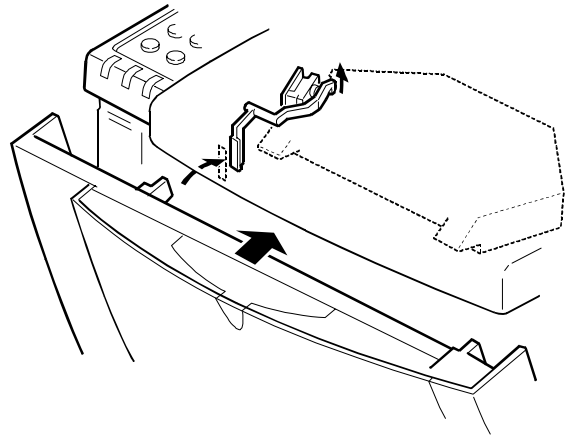

G094R514.WMF

3.3.2 UPPER COVER

Open the front cover and rear cover. Then remove the AIO.

- [A]: Operation panel (2 hooks)
- [B]: Upper exit cover
- [C]: Open the exit guide plate.
- [D]: Upper cover (⌀ x 4)

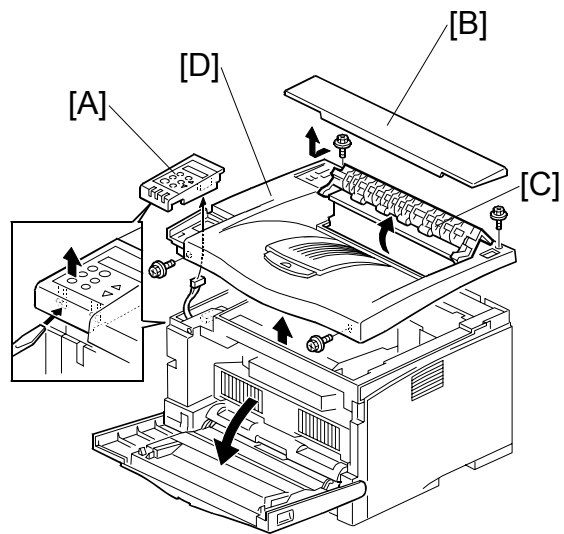

G091R201.WMF

3.3.3 BY-PASS TRAY UNIT

NOTE: Remove the by-pass tray unit before removing the exterior covers.

[A]: By-pass tray unit (2 hooks)

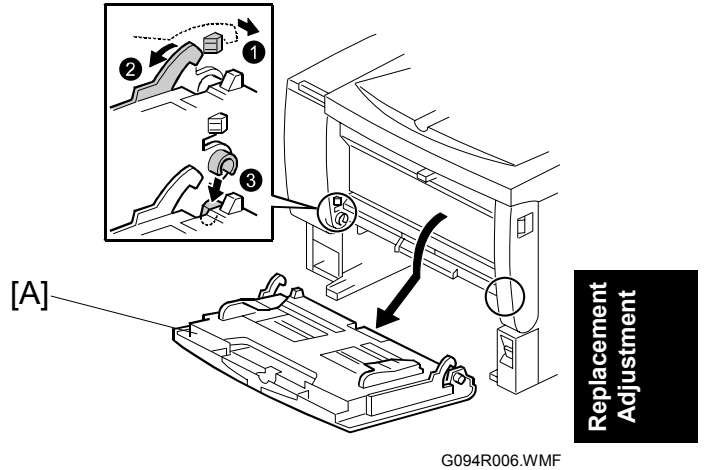

G094R006.WMF

3.3.4 EXTERIOR COVERS

To remove the left or right cover, separate the machine from the optional paper tray unit first.

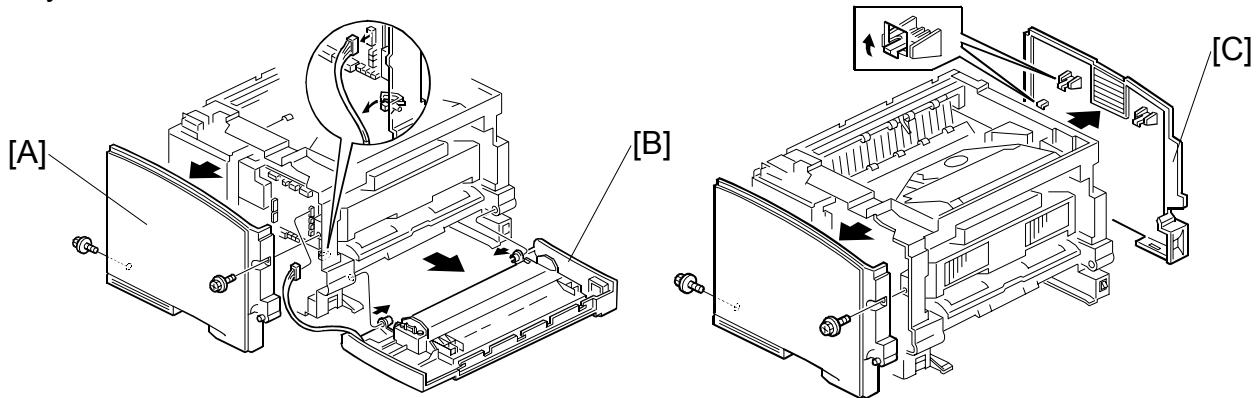

G091R702.WMF

G091R703.WMF

Open the front cover.

[A]: Left cover (⚙ x 2)

[B]: Front cover (3 clamps, 2 harnesses)

[C]: Right cover (3 hooks)

NOTE: Pull out the standard paper tray before removing the front cover.

3.4 LASER UNIT

⚠ WARNING
Turn off the main power switch and unplug the machine before attempting any of the procedures in this section. Laser beams can seriously damage your eyes.

3.4.1 CAUTION DECAL LOCATIONS

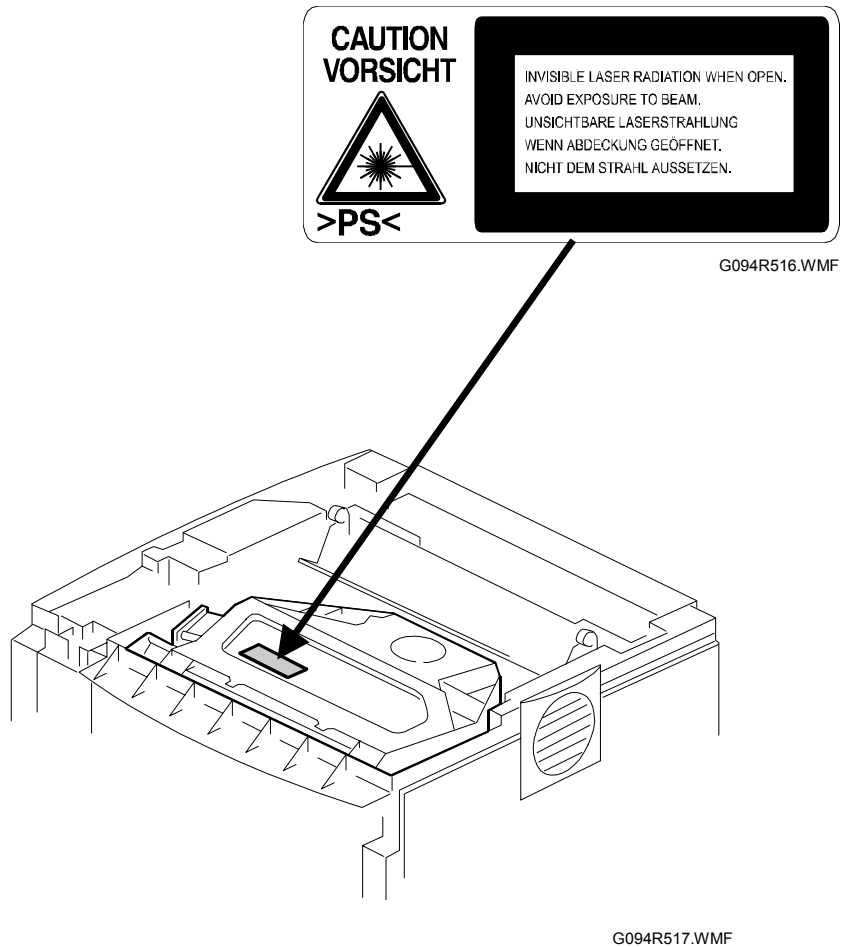

3.4.2 POLYGON MIRROR MOTOR

⚠ WARNING

Turn off the main switch and unplug the machine before attempting any of the procedures in this section. Laser beams can seriously damage your eyes.

Upper cover (☛ 3.3.2)

[A]: Polygon mirror cover (🔩 x 2)

[B]: Polygon mirror motor (🔩 x 4,
🔌 x 1)

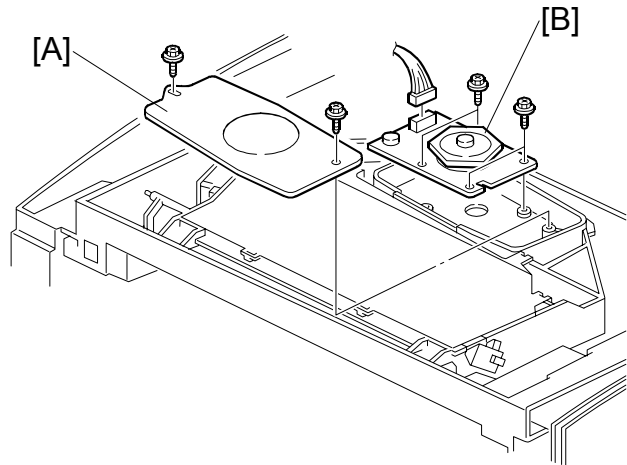

G094R518.WMF

Replacement
Adjustment

NOTE: Do not touch the surface of the mirror with bare hands.

3.4.3 LASER SYNCHRONIZATION DETECTOR

Upper cover (☛ 3.3.2)

By-pass tray unit (☛ 3.3.3)

Exterior covers (3.3.4)

[A]: Laser synchronization detector (🔌 x 1)

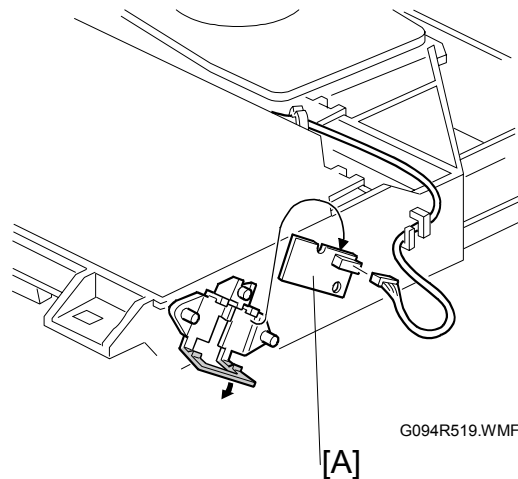

G094R519.WMF

3.4.4 LASER UNIT

Upper cover (☛ 3.3.2)

Exterior cover (☛ 3.3.4)

[A]: Clip

[B]: Laser unit (⚙ x 4, 1 flat cable,
🔌 x 2)

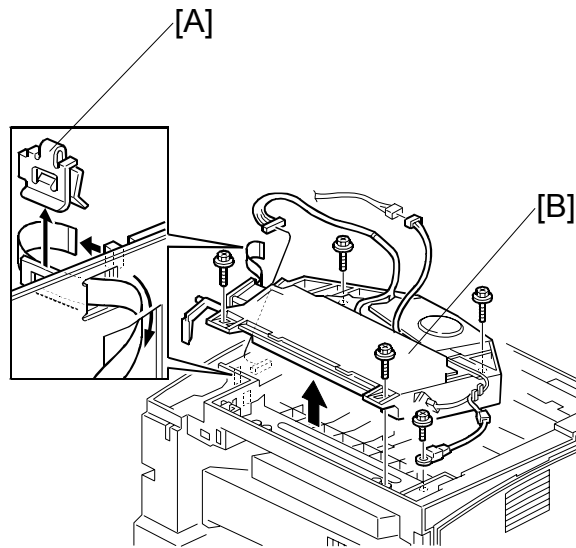

When reinstalling the laser unit

G091R203.WMF

Use the scanner positioning pin (P/N: A0069104) to reinstall the unit.

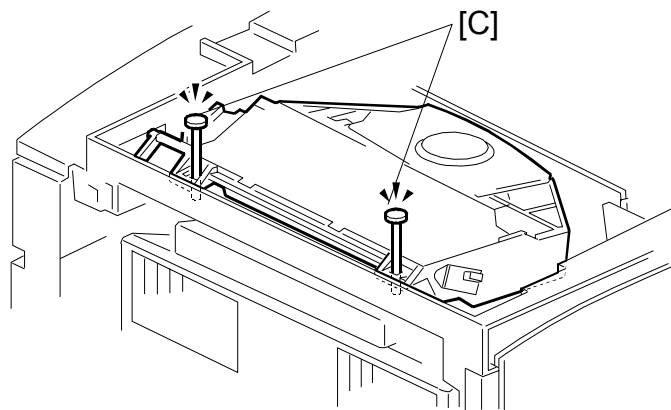

G091R208.WMF

[C]: Set the positioning pins as shown above. Then secure the laser unit.

3.4.5 LASER DIODE UNIT

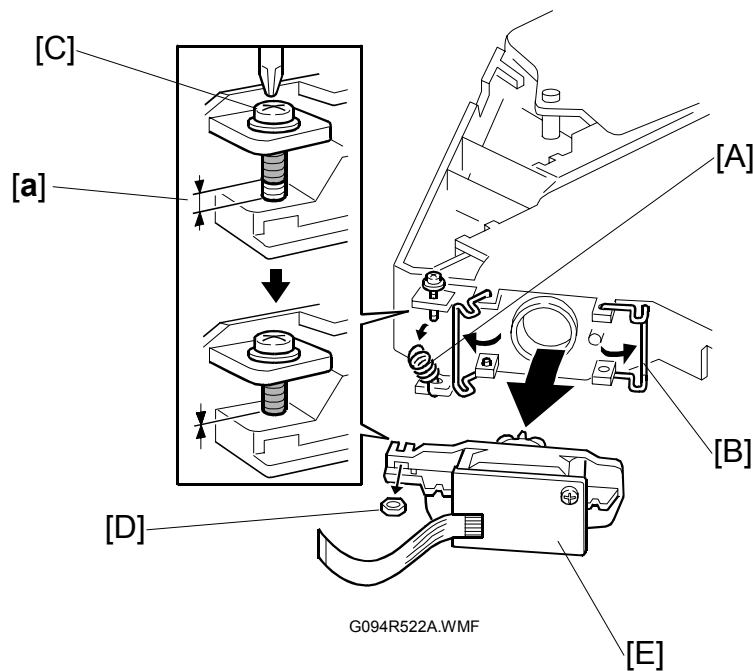

Replacement
Adjustment

Laser Unit (☛ 3.4.4)

- [A]: Spring
- [B]: LD unit holders (x 2)
- [C]: Loosen the screw
- [D]: Nut
- [E]: LD Unit

NOTE: 1) Do not remove the screws that secure the LD board.
2) Do not touch any variable resistors on the LD board.

When installing the LD Unit:

Tighten the screw [C] until the unpainted portion of the screw [a] is not visible.

After installing the LD unit, check the test pattern for the final adjustment (see the following procedure).

3.4.6 LASER BEAM PITCH ADJUSTMENT

1. Print out the following test patterns – cross-stitch pattern and two-dot argyle pattern.
 - Select the test pattern with SP 2902.
 - After selecting a pattern, the display automatically goes to SP 5902. Use SP 5902-1 to print one test pattern.
 - After completing the adjustment, reset SP 2902 to 'no specified'.
2. Check these test patterns. If the laser beam pitch is not correct, the images are as follows.
 - Cross-stitch pattern: Vertical black strips seem to appear.
 - Argyle pattern: The density of the diagonal lines is light or the lines have disappeared.
3. Adjust the LD unit holder position: Tighten or loosen the screw [C] (see the previous page) until the printout appears as follows.
 - Cross-stitch pattern: The thin lines are of uniform thickness (no striping effect should appear on the printout).
 - Grid pattern: The diagonal lines appear clearly and are of normal density.

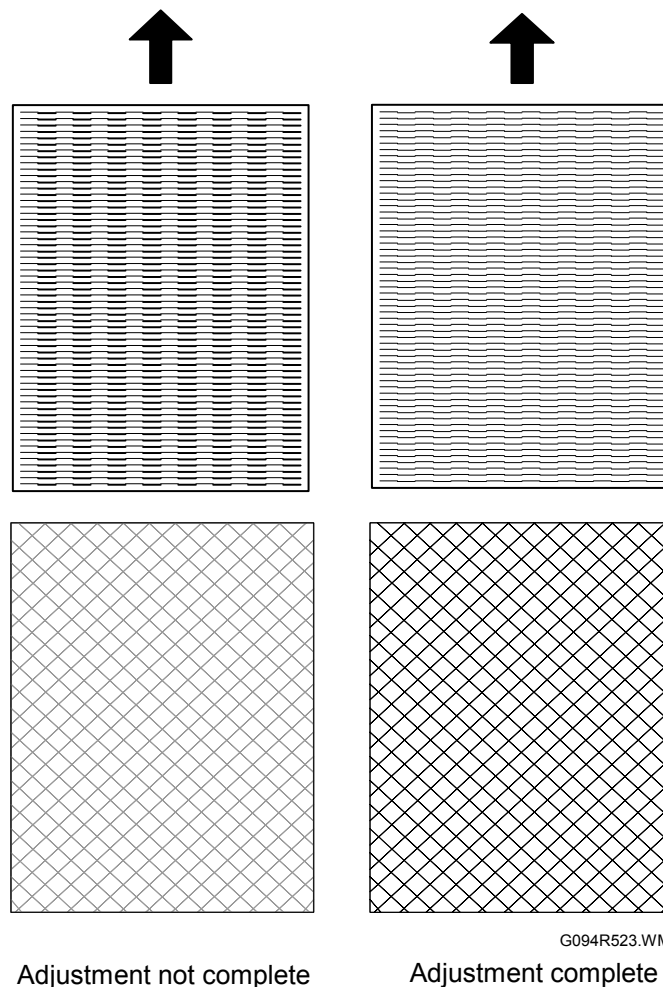

3.5 TRANSFER ROLLER

Remove the AIO.

[A]: Transfer roller

NOTE: Do not touch the transfer roller surface.

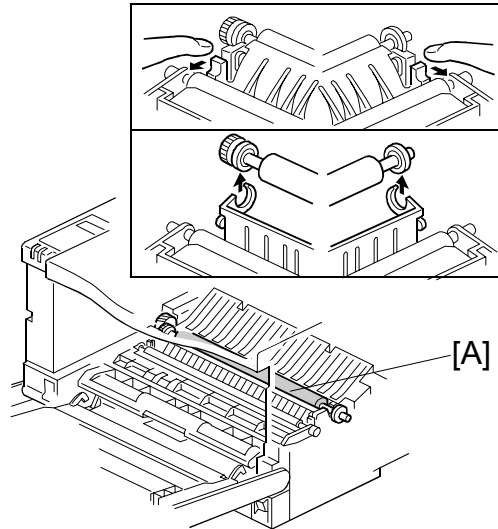

Replacement
Adjustment

G094R524.WMF

3.6 TONER END SENSOR

Remove the AIO.

[A]: Toner end sensor (4 hooks,
☞ x 1)

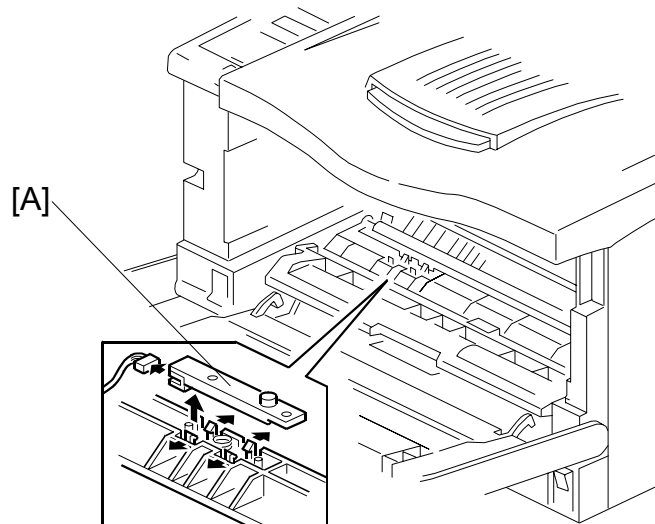

G094R525.WMF

3.7 FUSING

⚠ CAUTION

Allow time for the unit to cool before doing the following procedure.

3.7.1 FUSING UNIT

[A]: Rear cover

[B]: Fusing unit (2 hooks [C])

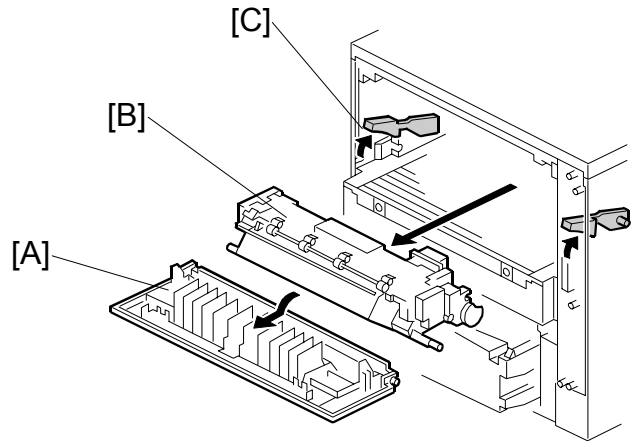

G094R007.WMF

NOTE: Lift both hooks before attempting to remove the fusing unit from the machine.

3.7.2 HOT ROLLER AND FUSING LAMP

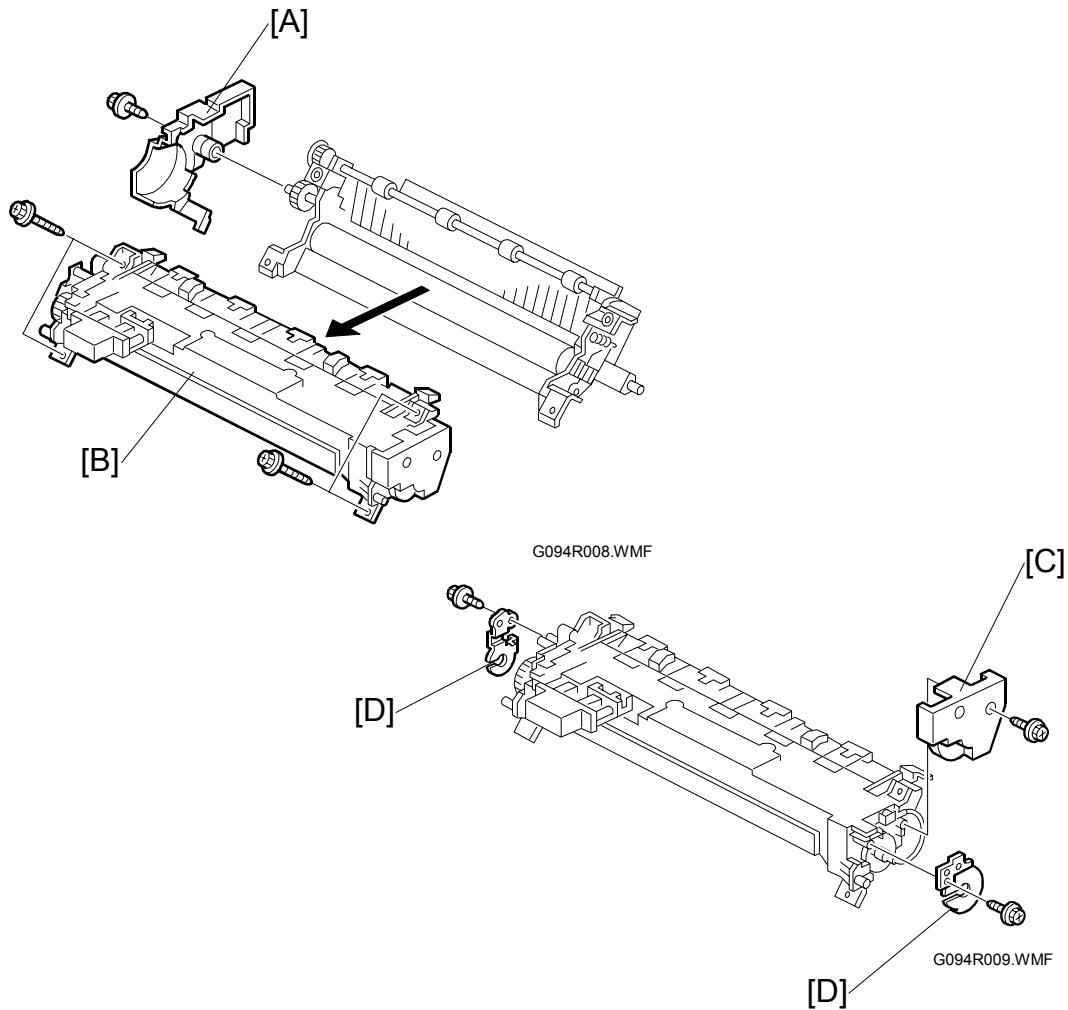

Replacement
Adjustment

Fusing Unit (☛ 3.7.1)

[A]: Left cover (☛ x 1)

[B]: Upper fusing unit assembly (☛ x 4, 2 springs)

[C]: Right cover (☛ x 1)

[D]: Lamp holders (☛ x 1 each)

NOTE: 1) Remove both springs before taking apart the fusing unit assembly. The reason for this is to relieve pressure on the unit.

2) When reinstalling the fusing unit assembly, install both springs last. The reason for this is to reset the springs back to their default position.

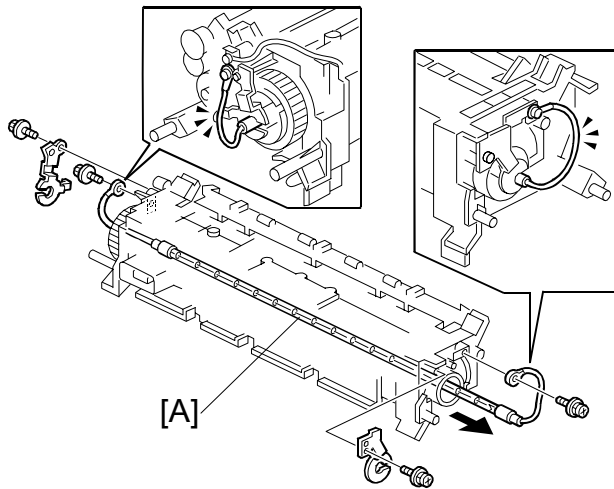

G094R526.WMF

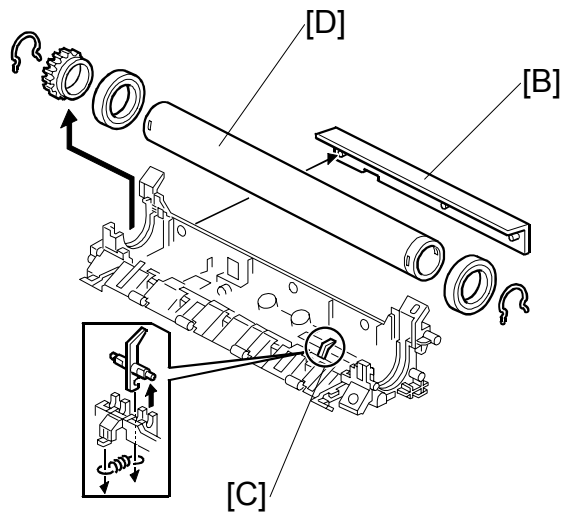

G094R003_CHN.WMF

[A]: Fusing Lamp ( x 2)

NOTE: The colored cable must be at the hot roller gear side.

[B]: Guide plate (3 hooks)

[C]: Hot roller strippers (1 spring each)

[D]: Hot roller (2 C-rings, 1 gear, 2 bushings)

- NOTE:**
- 1) Take the gear and the pin off first, before removing the hot roller from the unit.
 - 2) Use a small screwdriver to separate the guide plate from the unit.
 - 3) Before installing the new hot roller, peel off 3 cm (1 inch) from both ends of the protective sheet on the new hot roller. Make sure to remove the rest of the paper before starting the machine.

3.7.3 PRESSURE ROLLER

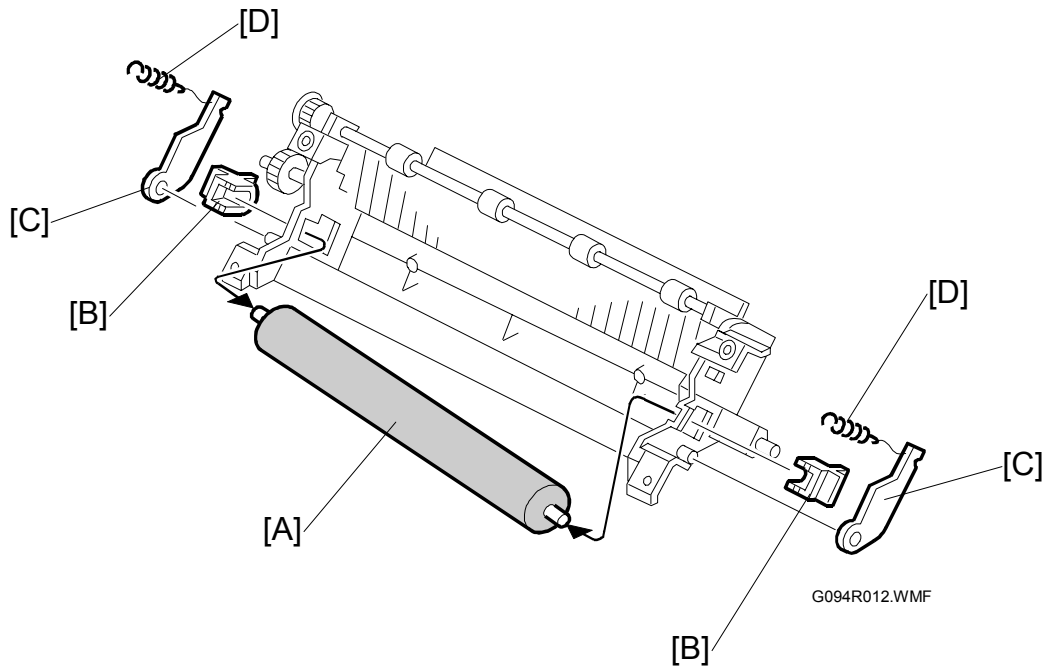

Replacement
Adjustment

Fusing Unit (☛ 3.7.1)

Hot roller and fusing lamp (☛ 3.7.2)

[A]: Pressure roller

[B]: Bushing

[C]: Pressure roller lever

[D]: Spring

3.7.4 THERMISTOR AND THERMOSTAT

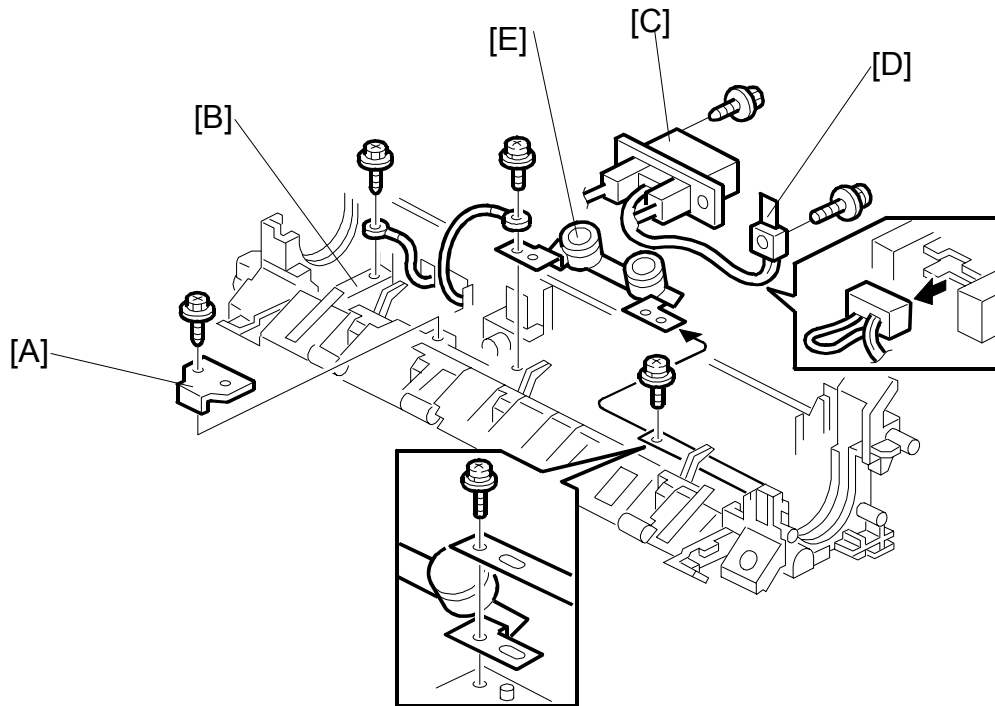

G094R011.WMF

Hot roller and fusing lamp (☛ 3.7.2)

[A]: Wire cover (🔩 x 1)

[B]: Grounding plate (🔩 x 2, 1 wire)

[C]: Fusing unit connector (🔩 x 6, 📏 x 1, 2 hooks)

[D]: Thermistor (🔩 x 1, 1 harness)

[E]: Thermostat (🔩 x 1)

NOTE: 1) When removing the thermistor, remove the entire unit first and then separate it into two parts.

2) Do not touch the thermostat with your hands.

3.7.5 HOT ROLLER STRIPPERS

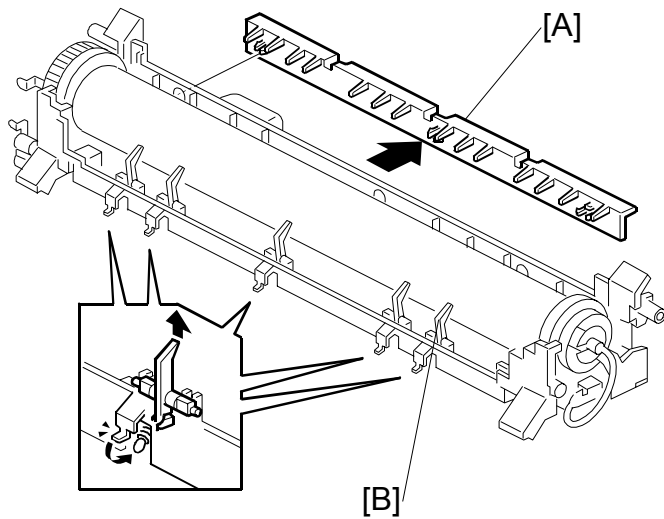

G091R510.WMF

Replacement
Adjustment

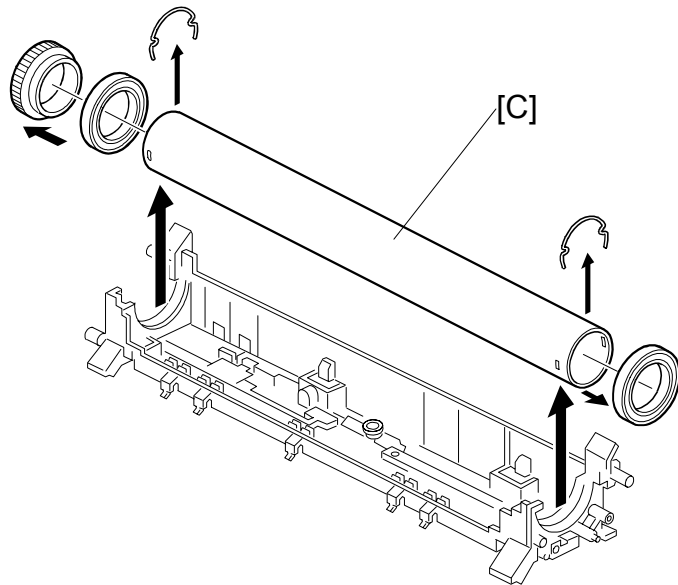

G091R505.WMF

- [A]: Guide plate (3 hooks)
- [B]: Hot roller strippers (1 spring each)
- [C]: Hot roller (2 C-rings, 1 gear, 2 bushings).

NOTE: Before installing the new hot roller, peel off 3 cm (1 inch) from both ends of the protective sheet on the new roller. Also, remove the rest of the paper before starting the machine.

3.8 PAPER FEED

3.8.1 PAPER FEED ROLLER

[A]: Paper feed roller

NOTE: Pull out the paper tray before removing the paper feed roller.

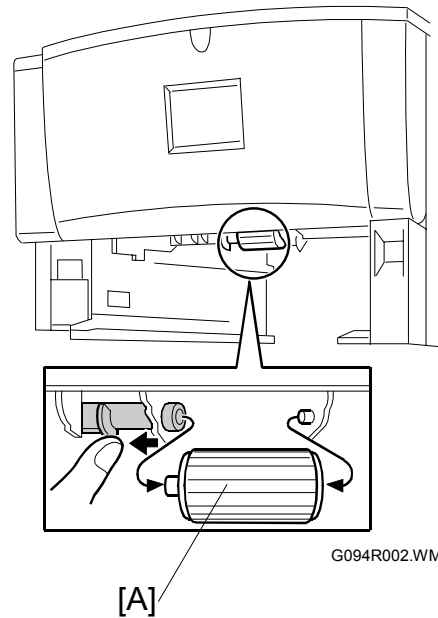

3.8.2 FRICTION PAD

[A]: Friction pad (2 hooks, 1 spring)

NOTE: Remove the paper tray unit from the machine before removing the friction pad.

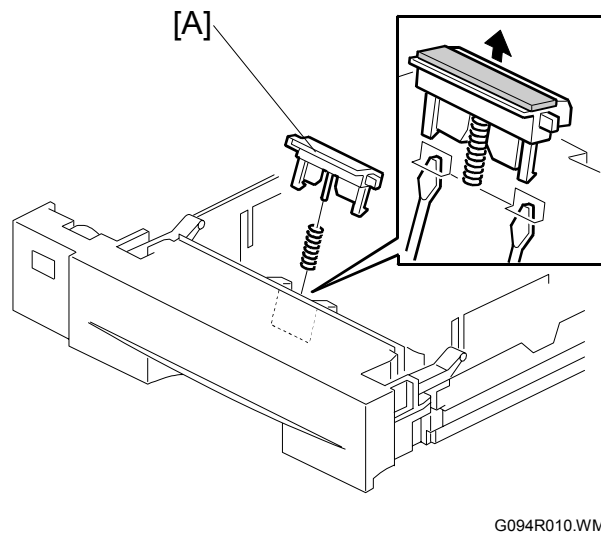

When reinstalling the friction pad follow this order

1. Replace the spring.
2. Insert the right side of the friction pad first followed by the left side.
3. Gently push the friction pad down into the slot and then pull forward very slightly.

3.9 BY-PASS TRAY

3.9.1 BY-PASS TRAY UNIT AND BY-PASS FEED ROLLER

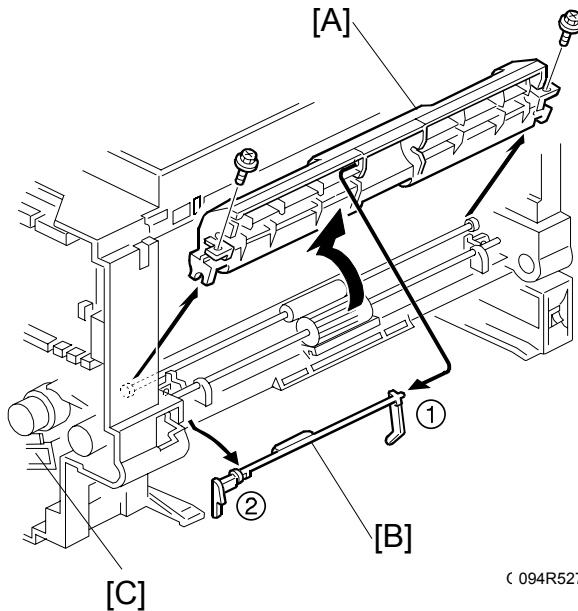

Left Cover (☛ 3.3.4)

Front Cover (☛ 3.3.4)

Remove the AIO.

[A]: Paper guide (☛ x 2)

[B]: Actuator

[C]: Solenoid (☛ x 1)

[D]: By-pass feed roller

[E]: Gear (1 hook)

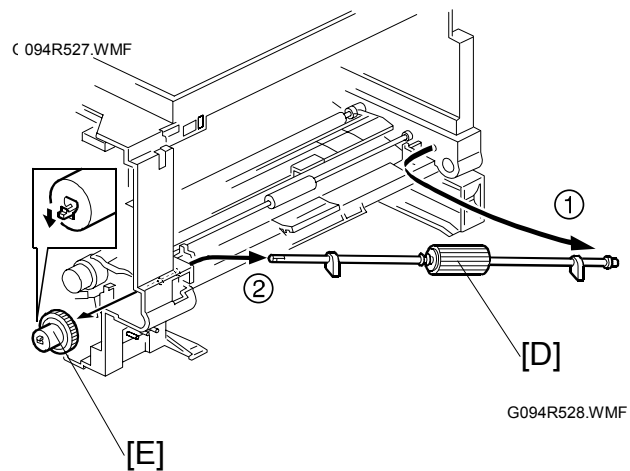

Replacement
Adjustment

When reinstalling the paper guide.

1. Set the paper guide on the bushing.
2. Install the right part of the actuator on the paper guide.
3. Install the left part of the actuator in the machine.
4. Install the paper guide.
5. Check that the actuator moves smoothly and swings freely.

3.10 PRINTER CONTROLLER BOARD

[A]: Printer controller board (⌀ x 2)

[B]: NVRAM

NOTE: Remove the NVRAM from the old printer controller board and insert it on the new board.

- NOTE:**
- 1) Remove the Duplex Unit before you remove the controller board.
 - 2) The screws on the printer controller board are hand screws. Gently turn these screws when removing the printer control board.
 - 3) Pull on the handle to remove the printer controller board from the machine.

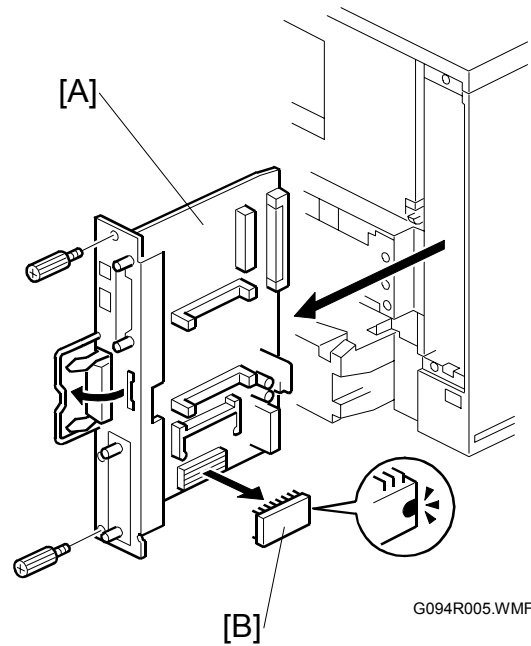

3.11 ENGINE BOARD

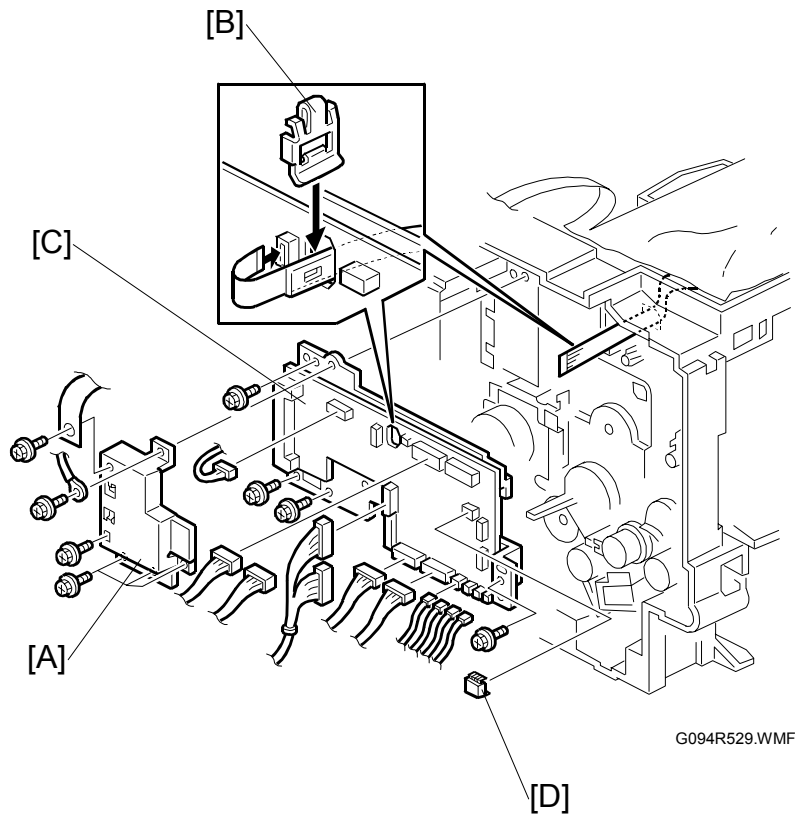

Replacement
Adjustment

Left cover (☛ 3.3.4)

Printer controller board (☛ 3.10)

[A]: Bracket (⚙ x 7, 1 grounding wire)

NOTE: Be careful not to damage the flat cable.

[B]: Clip

[C]: Engine board (⚙ x 4, all connectors)

NOTE: Remove the NVRAM [D] from the old engine board and insert it on the new board.

3.12 MAIN MOTOR

Left cover (☛ 3.3.4)

[A]: Main motor (⚙️ x 4, 🛠️ x 1)

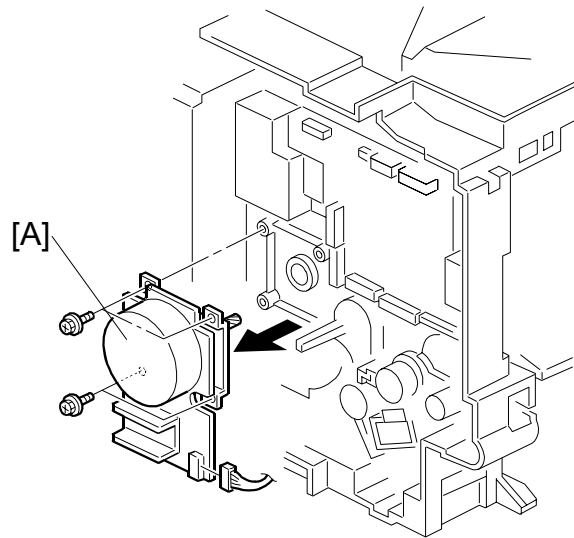

G094R530.WMF

3.13 SOLENOIDS AND CLUTCHES

Left cover (☛ 3.3.4)

[A]: By-pass feed solenoid

(⚙️ x 1, 🛠️ x 1)

[B]: Gear (1 hook)

[C]: Stopper (⚙️ x 1)

[D]: Relay clutch (🛠️ x 1 🛠️ x 1)

[E]: Paper feed clutch (🛠️ x 1)

Main motor (☛ 3.12)

[F]: Registration clutch

(🛠️ x 1 🛠️ x 1)

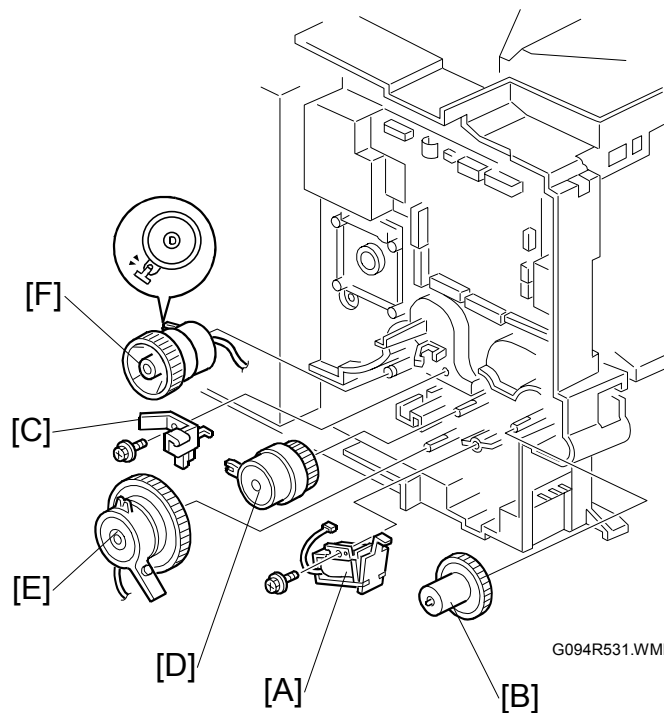

G094R531.WMF

3.14 POWER SUPPLY BOARD AND HIGH VOLTAGE SUPPLY BOARD

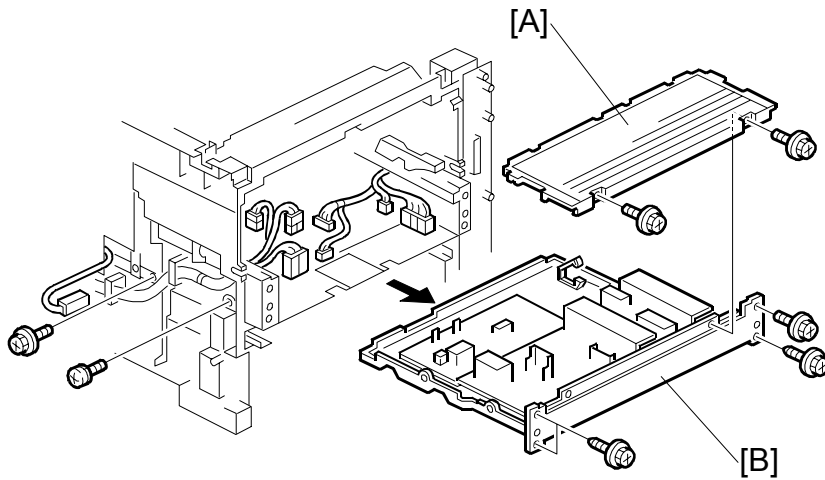

G094R004.WMF

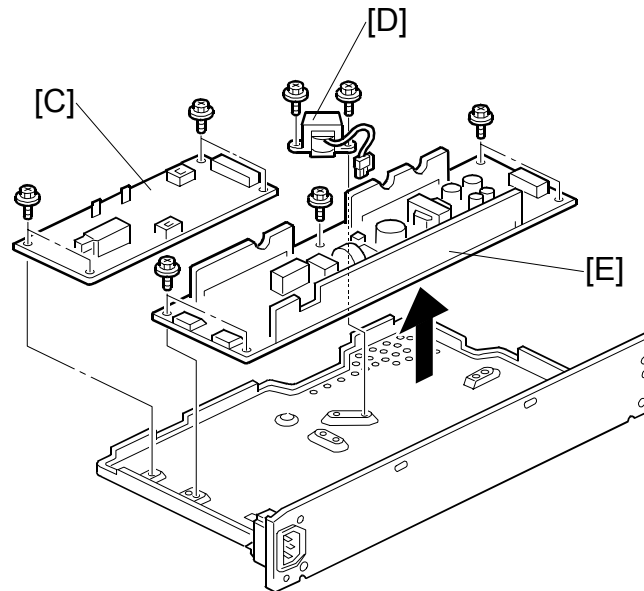

G094R532.WMF

Replacement
Adjustment

Left cover (☛ 3.3.4)

Fusing unit (☛ 3.7.1)

[A]: PSU cover (🔩 x 2)

[B]: PSU assembly (🔩 x 7, all connectors)

[C]: High voltage supply board (🔩 x 4)

[D]: Choke coil (🔩 x 2 📏 x 1)

[E]: PSU (🔩 x 5)

3.15 COOLING FAN

Right cover (☛ 3.3.4)

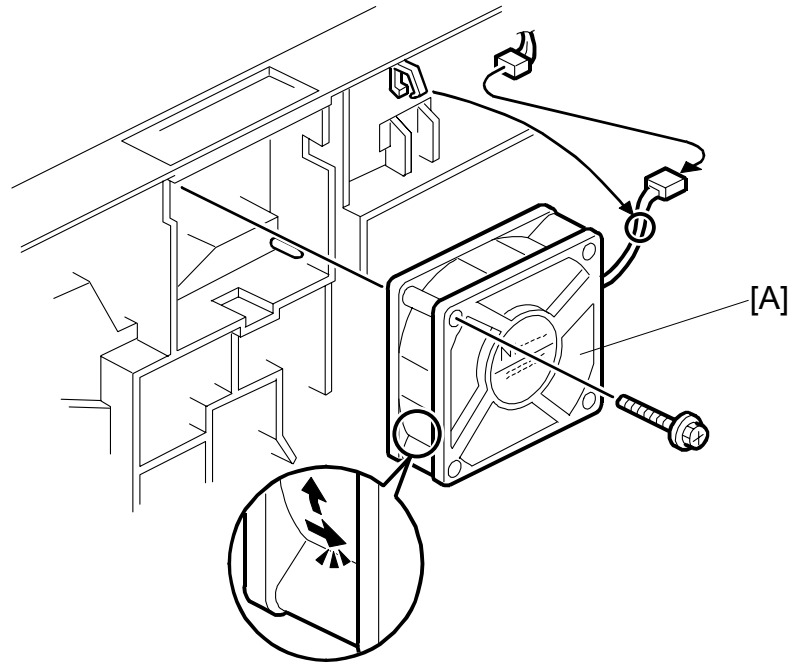

G094R501.WMF

[A]: Cooling fan (☛ x 1, ☛ x 1)

NOTE: The cooling fan must be reinstalled to the original position. Do not reinstall the cooling fan opposite to the original position.

3.16 IMAGE ADJUSTMENT

3.16.1 REGISTRATION ADJUSTMENT

The registration is adjusted using the user mode; "Maintenance-Registration". For details, see the Printer Reference operation manual.

3.16.2 PARALLELOGRAM IMAGE ADJUSTMENT

NOTE: Use the scanner-positioning pin (P/N: A0069104) for the adjustment.

Do the following procedure if a parallelogram is printed while adjusting the printing registration using a trimming pattern.

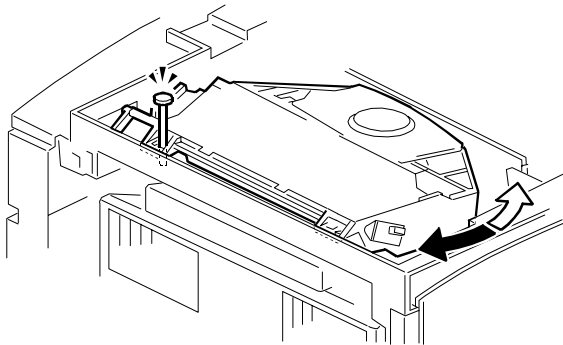

G094R533.WMF

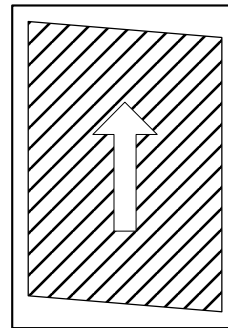

(a)

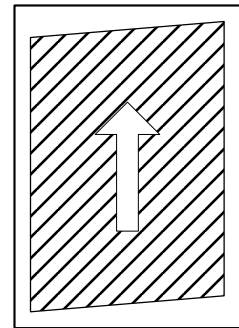

(b)

G094R500.WMF

Replacement
Adjustment

1. Remove the upper cover (☛ 3.3.2)
2. Put a positioning pin in one of the holes
3. Loosen four screws and move the laser unit.
4. Tighten the laser unit.
5. Print the trimming area pattern to check the image. If it is still the same, repeat steps 3 to 5.

4. TROUBLESHOOTING

4.1 SERVICE CALL CONDITIONS

The SC codes in this section are for the G091 China model machine.

4.1.1 SUMMARY

There are 2 levels of service call conditions.

Level	Definition	Reset Procedure
A	Only a service representative can reset this SC. This will prevent damage to the machine. You cannot use the machine.	<i>Enter engine SP mode 5810 and press “#”. When ‘execute’ is displayed, press “#” again. Then press ‘Escape’. Then turn the main power off/on.</i>
B	The SC can be reset by turning the operation switch off and on, if the SC was caused by a sensor error.	Set the main power off and on.

- NOTE:** 1) If the problem is with electrical circuit boards, disconnect the connectors first. Then reconnect the connectors before you replace the PCBs.
2) If the problem is with a motor lock, first examine the mechanical load. Then replace motors or sensors.

4.1.2 SC CODE DESCRIPTIONS

Code No.		Symptom	Possible Cause
302	B	Charge roller current leak	<ul style="list-style-type: none"> • Cartridge (charge roller) defective • High voltage supply board defective • Defective cartridge connection
		A charge roller current leak signal is detected.	
320	B	Polygon motor error	<ul style="list-style-type: none"> • Polygon motor • Polygon motor cable
		The polygon motor does not reach its operating speed within 10 seconds after the polygon motor on signal, or the lock signal is not detected for more than a certain time during operation.	
322	B	1st laser synchronization error	<ul style="list-style-type: none"> • Laser synchronization detector board out of position • Laser synchronization detector board or cable defective • Laser synchronization mirror out of position • LD unit defective • Engine board defective
		The laser synchronization detector cannot detect the laser synchronization signal for more than 5 consecutive 100 ms intervals.	
323	B	LD drive current exceeded	<ul style="list-style-type: none"> • LD unit defective
		The LD driver detects this error for more than 500 ms.	
326	B	2nd laser synchronization error	<ul style="list-style-type: none"> • Laser synchronization detector board out of position • LD unit defective • Engine board defective
		The 1st LD1 is already on, but the laser synchronization detector cannot detect the laser synchronization signal from the 2nd LD for more than 5 consecutive 100 ms intervals.	
391	B	Development bias leak	<ul style="list-style-type: none"> • High voltage supply board defective • Defective cartridge connection
		A development bias leak signal is detected.	
500	B	Main motor lock	<ul style="list-style-type: none"> • Main motor defective • Too much load on the drive mechanism
		A main motor lock signal is not detected for more than 700 ms after the main motor starts to rotate, or the lock signal is not detected for more than a certain time during rotation after the last signal.	
541	A	Unstable fusing temperature	<ul style="list-style-type: none"> • Thermistor defective • Fusing lamp open • Fusing thermostat open • Power supply board defective • Defective connection of the fusing unit
		During warm-up, the fusing temperature rises by less than 20 °C during 11 seconds.	
		The fusing temperature detected by the thermistor was 0 °C 5 seconds after the fusing relay was turned on.	

Code No.		Symptom	Possible Cause
542	A	Fusing temperature warm-up error	<ul style="list-style-type: none"> • Thermistor defective • Fusing lamp open • Fusing thermostat open • Power supply board Defective • Defective connection of the fusing unit
		The fusing temperature does not reach more than 80 °C 17.5 seconds after the main switch is turned on.	
543	A	Fusing overheat error	<ul style="list-style-type: none"> • Fusing thermistor defective • Power supply board defective
		A fusing temperature of over 245 °C is detected for 1 second by the fusing thermistor.	
		A fusing temperature of over 235 °C is detected for 1 second after the fusing lamp has been turned off.	
544	A	Fusing overheat error (hardware circuit detection)	<ul style="list-style-type: none"> • Power supply unit defective • I/O board (IOB) defective • BICU defective • Fusing thermistor defective
		The dual monitoring circuitry of the BICU detects extremely high temperature and tripped the relay circuit off.	
545	A	Fusing lamp stays on	<ul style="list-style-type: none"> • Fusing thermistor defective • Power supply board defective • Defective connection of the fusing unit
		The fusing lamp stays on more than 12 seconds after the main motor has been turned off.	
546	A	Unstable fusing temperature	<ul style="list-style-type: none"> • Fusing thermistor defective • Power supply board defective • Defective connection of the fusing unit
		During standby, within 500 ms, the fusing temperature goes below 60 °C twice or over 60 °C three times.	
		Within 1 minute, a 60 °C increase or decrease in fusing temperature is detected during five different one-second intervals.	
547	B	Zero cross signal malfunction	<ul style="list-style-type: none"> • Power supply board defective • Defective mains power supply condition
		Zero cross signals are not detected within 5 seconds.	
		The CPU detects an exhaust fan lock signal for more than 3.5 seconds.	
610	B	Communication error - duplex unit	<ul style="list-style-type: none"> • Defective connection between engine board and duplex unit • Engine board defective • Duplex control board defective
		The engine board cannot communicate with the duplex unit.	

Code No.		Symptom	Possible Cause
650	B	Communication error - GAVD	<ul style="list-style-type: none"> • Engine board defective
		<ul style="list-style-type: none"> • The engine board detects an unknown device on the I²C I/F bus (internal bus on the engine control board). • The engine board detects an I²C I/F bus error. 	
651	B	Communication error - FCI	<ul style="list-style-type: none"> • Engine board defective
		<ul style="list-style-type: none"> • The engine board detects an unknown device on the I²C I/F bus (internal bus on the engine control board). • The engine board detects an I²C I/F bus error. 	
726	B	Shift tray motor error	<ul style="list-style-type: none"> • Shift motor defective • Shift tray: Left shift sensor or right shift sensor defective
		Tray shift did not finish within a certain time after the shift motor turned on.	

4.2 CONTROLLER ERROR

The following table describes the controller error codes. These codes are displayed at power-on, or after the power-on self test, if an error occurs.

Code	Description	Required Action
640	Engine to controller communication error.	<ul style="list-style-type: none"> Examine the connection between the controller and the engine board. Replace the engine board if the error is frequent. Replace the controller if the error is frequent.
641	Engine to controller communication error (no answer).	<ul style="list-style-type: none"> Examine the connection between the controller and the engine board. Replace the engine board if the error is frequent.
670	Engine response error	<ul style="list-style-type: none"> Engine board installed incorrectly Engine board defective Controller board defective
671	Controller-to-operation panel communication error at startup	<ul style="list-style-type: none"> Controller stalled Controller board installed incorrectly Controller board defective Operation panel connector loose or defective
800	Video data error	<ul style="list-style-type: none"> Examine the connection between the controller and the engine board. Replace the engine board if the error is frequent.
818	System timeout error	<ul style="list-style-type: none"> Defective controller Replace the controller if it occurs frequently.
819	Kernal end error	<ul style="list-style-type: none"> HDD error Software application error RAM shortage
820	Controller CPU error	<ul style="list-style-type: none"> Replace the controller if the error is frequent.
821	CPU and ASIC timer error	<ul style="list-style-type: none"> Turn off the machine and turn it back on. Replace the controller if the error is frequent.
822	HDD timeout error	<ul style="list-style-type: none"> Examine the connection between the HDD and the controller Replace the HDD if the error is frequent.
823	NIB self test error	<ul style="list-style-type: none"> Turn off the machine and turn it back on. Examine the connection between the NIB and the controller. Replace the NIB if the error is frequent.
824	NVRAM error	<ul style="list-style-type: none"> Replace the NVRAM if the error is frequent.
827	SDRAM error	<ul style="list-style-type: none"> Replace the controller if the error is frequent.
828	Flash ROM error	<ul style="list-style-type: none"> Replace the controller if the error is frequent.
829	Optional RAM error	<ul style="list-style-type: none"> Examine the connection of the optional memory. Replace the optional memory if the error is frequent.
835	Parallel interface error	<ul style="list-style-type: none"> Replace the controller if the error is frequent.
836	Font ROM error	<ul style="list-style-type: none"> Not used for this model.
837	Optional font ROM error	<ul style="list-style-type: none"> Not used for this model.
838	Clock generator error	<ul style="list-style-type: none"> Replace the controller if the error is frequent.

Code	Description	Required Action
850	NIB interface error	<ul style="list-style-type: none"> • Replace the controller if the error is frequent.
857	USB I/F Error	<ul style="list-style-type: none"> • The USB driver can generate three types of errors: RX, CRC, and STALL errors. Only the STALL error can generate this SC code. • Defective controller board
860	HDD start-up error	<ul style="list-style-type: none"> • Turn off the machine and turn it back on. • Examine the connection between the HDD and the controller. • Replace the HDD if the error is frequent.
862	HDD damaged cluster error	<ul style="list-style-type: none"> • Replace the HDD if the error is frequent.
863	HDD data unable to read	
864	HDD data access error	
865	HDD access error	
900	Controller counter error	<ul style="list-style-type: none"> • Replace the NVRAM if the error is frequent.
990	Software performance error	<ul style="list-style-type: none"> • Software defective; reboot the machine • Internal parameter incorrect • Insufficient working memory • When this SC occurs, the file name, address, and data will be stored in NVRAM. <p>Note the above data and the situation in which this SC occurs. Then report the data and conditions to your technical control center.</p>
991	Software continuity error	<ul style="list-style-type: none"> • Software bug; reboot the machine • Internal parameter incorrect • Insufficient working memory
998	Application start error	<ul style="list-style-type: none"> • Software defective; change the firmware for the application that failed • An option required by the application (RAM, DIMM, board) is not installed
999	Software update error	<ul style="list-style-type: none"> • Try downloading the controller software again.

4.3 ELECTRICAL COMPONENT DEFECTS

4.3.1 SENSORS

Component	CN	Condition	Symptom
Paper Exit	6-B2	Open	The Paper Jam indicator will light whenever a print is made.
		Shorted	The Paper Jam indicator lights even if there is no paper.
Paper Overflow	6-B5	Open	The paper overflow message is not displayed even when a paper overflow condition exists.
		Shorted	The paper overflow message is displayed.
Registration	16-A2	Open	The Paper Jam indicator will light whenever a print is made.
		Shorted	The Paper Jam indicator lights even if there is no paper.
Remaining paper sensor 1	16-A5	Open	The Paper End indicator lights even if paper is placed in the 1st paper tray.
		Shorted	The Paper End indicator does not light even if there is no paper in the 1st paper tray.
Remaining paper sensor 2	16-A8	Open	The machine cannot determine the paper near-end condition properly.
		Shorted	
Toner End	16-A12	High	Toner near-end (toner end) is not detected.
		Low	The add toner message is displayed.

Trouble-shooting

NOTE: The CN numbers describe the connector number on the engine board.

4.3.2 SWITCHES

Component	CN	Condition	Symptom
Main	270-1,2	Open	The machine does not turn on.
		Shorted	The machine does not turn off.
Front Cover Safety	9-1	Open	The Front Cover Open message is not displayed even if the front cover is opened.
		Shorted	The Front Cover Open message is displayed even if the front cover is closed.
Rear Cover Safety	9-3 5-3	Open	The Rear Cover Open message is not displayed even if the rear cover or paper exit cover is opened.
		Shorted	The Rear Cover Open message is displayed even if the rear cover or paper exit cover is closed.

NOTE: The CN numbers describe the connector number on the engine board (except for the main switch).

4.4 BLOWN FUSE CONDITIONS

Fuse	Rating	Symptom when turning on the main switch
	220 - 240 V	
Power Supply Board		
FU1	----	Machine does not start
FU2	3.15 A/250 V	Machine does not start
FU3	5 A/250 V	Machine does not start
FU4	5 A/250 V	Machine does not start (The LEDs turn on for a moment.)

4.5 LEDES

No LEDs are used for this model (except for the NIB - refer to section 6.7).

5. SERVICE TABLES

5.1 SERVICE PROGRAM MODE

The Service Program Modes in this section are for the G091 China model machine.

⚠ CAUTION

Before accessing the service menu, do the following:

Confirm that there is no print data in the printer buffer (the Data In LED must not be lit or blinking).

If there is some data in the buffer, wait until all data has been printed.

5.1.1 ENABLING AND DISABLING SERVICE PROGRAM MODE

Entering the Service Mode

There are two ways to enter the service mode.

Method 1: Turn the machine on while pressing the “On Line” key and “Escape” key together until “1. Service Menu1” appears on the display.

NOTE: If you switch the machine off, any jobs stored on the hard disk using the sample print and protected print features will be deleted. Check first with the user tools to see if there are any jobs stored with these features (Menu key - Sample Print, or Protected Print).

Method 2: Press the “Up/Down arrow” keys together for about 5 seconds, then press the “Enter” key.

“1. Service Menu1” appears on the display.

NOTE: The machine automatically goes off line when you enter the service mode

Inputting a Value or Setting for a Service Program

Enter the required program mode as explained above. The setting appearing on the display is the current setting.

Select the required setting using the “Up/Down arrow” keys, then press the “Enter” key. The previous value remains if the “Enter” key is not pressed.

Exiting Service Mode

Select “3. End” from the service mode main menu, then press the “Enter” key.

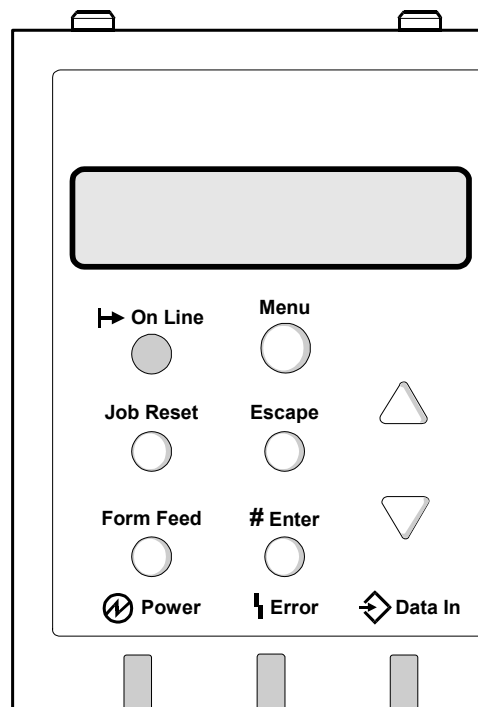

G094S509.WMF

5.2 PRINTER CONTROLLER SERVICE MODE

5.2.1 SERVICE MODE MENU (“1. SERVICE MENU”)

Service Mode	Description	Function
1001	Bit switch	Adjusts bit switch settings. Note: Currently the bit switches are not being used.
1003	Clear Setting	Initializes settings in the “System” menu of the user mode.
1004	Print summary	Prints the service summary sheet (a summary of all the controller settings).
1005	Disp Version	Displays the version of the controller firmware.

5.2.2 BIT SWITCH PROGRAMMING

NOTE: Currently, the bit switches are not being used.

1. Enter the SP mode, select “Service Menu”, then press [Enter] twice.

```
Service Menu
BitSW
```

2. Select #1, #2, #3, or #4 for the desired bit switch, then press [Enter].

```
BitSW
<BitSW#1>
```

- [▲] [▼]: Move to the next switch.

3. Adjust the bit switch using the following keys.

- [▲] [▼]: Move to the next bit.
- [Escape]: Exit without saving changes.
- [Enter]: Exit and save changes.

```
Sw#1  00000000
Bit0  _
```

NOTE: The left digit on the display is bit 7 and the right digit is bit 0.

4. Press [Enter] to save changes and exit.

5.3 PRINTER ENGINE SERVICE MODE

5.3.1 SERVICE MODE TABLE

Notation	What it means
[range / default / step]	Example: [-9 ~ +9 / +3.0 / 0.1 mm step]. The setting can be adjusted in the range ± 9 , value reset to +3.0 after an NVRAM reset, and the value can be changed in 0.1 mm steps with each key press.
<i>italics</i>	Comments added for reference.
DFU	Denotes "Design or Factory Use". Do not change this value.
Japan only	The feature or item is for Japan only. Do not change this value.

SP1-xxx: Feed

1003	Regist sag	
	Adjusts the relay clutch timing at registration. Relay clutch timing determines the amount of paper buckle at registration. (A "+" setting causes more buckling.)	
1003 1	Cassette	[-8 mm ~+8 mm/ 0 /2 mm step]
1003 2	Multi tray [By-pass]	[-8 mm ~+8 mm/ 0 /2 mm step]
1003 3	Duplex Tray	[-8 mm ~+8 mm/ 0 /2 mm step]

1104	Fusing control	Normal , Phase control
	Use phase control if the room lights flicker when the fusing lamp starts. Defaults: North America – Normal (On/off control), Europe – Phase	

1105	Fusing Temp.	
	Adjusts the fusing temperatures for printing and standby mode.	
1105 1	Fusing temp	[150 ~ 200/ 170 / 5 deg.] DFU
	Adjusts the fusing temperature for printing on normal paper.	
1105 2	Fusing T Stand	[140 ~ 175 / 168 / 1 deg.] DFU
	Adjusts the fusing temperature for standby mode.	

1106	Fusing T Display	
1106 1	Displays the current fusing temperature.	

1902	OHP clutch rt	1 = 1 rotation , 2 = 2 rotations
	Selects the number of rotations for the bypass feed roller when the paper type is set to "Transparencies". If jams occur when transparencies are being used, change the setting to 2.	

1910	Fusing start	Normal, Roller turn DFU
	Roller turn: Warms up the fusing unit for 20 s just after the power switch has been turned on or when the machine warms up from energy saver mode. Normal: There is no 20 s warm-up period. However, just after the main power switch is turned on, the motor turns to clean the drum.	

1912	Warm up control	Normal, Curl control
	Lowers the fusing temperature (to 150°C) to prevent thin paper from curling. Use this mode only when a paper jam occurs during duplex rear side printing.	

SP2-xxx: Drum

2001	Charge rol bias	[1000 ~ 2000 / -1675V / 10V step] DFU
	Adjusts the voltage applied to the charge roller for printing.	
2112	Mainscan mag	[-0.5% ~ 0.5% / 0 / 0.1% step]
	Adjusts the main scan magnification.	
2113	Subscan mag	[-0.5% ~ 0.5% / 0 / 0.1% step]
	Adjusts the sub scan magnification.	
2201	Developer bias	[200 ~ 800 / 750V / 10V step] DFU
	Adjusts the development bias for printing.	
2213	Toner end count	[50 ~ 200 / 200 / 50 sheets/step]
	Adjusts the number of prints the machine can make after it detects toner near-end.	
2301	Transfer curr	[-2 ~ 4 / 0 / 2 μ A/step]
	Adjusts the correction current applied to the transfer roller.	
2902	Test Pattern	
	Printing Test Pattern	No specified Various test patterns
	Selects a printer test pattern. After selecting a pattern, the display automatically goes to SP 5902. Use SP 5902 to print either one test pattern (5902-1) or a few of them (5902-2). <i>Reset SP 2902 to "no specified" after printing the test pattern, or the selected pattern will appear on every page printed by the user.</i>	
2910	Thermistor adj	Yes, No DFU
	If this is "Yes", the machine automatically adjusts the charge roller voltage and transfer current in response to the temperature within the machine.	
2928	Toner end clear	Execute DFU
	Clears the toner end counter in the engine board. Not used in this machine.	
2980	Waste toner cnt	
	Displays the waste toner counter in the engine board.	

SP3-xxx: Process

3921	Effective info	Not used: All items ignored Cartridge dtct: Cartridge detection only Normal mode (Cartridge detection and Type ID) All used: All items used
	Selects which of the cartridge ID chip functions are enabled.	

3922	Cartridge lmt	[15k ~ 40k / 30k / 5k step]
	Adjusts the number of prints the machine can make after a new cartridge is detected. Do not use a higher value than 30 k, or waste toner could leak from the waste toner tank.	

3923	Cartridge stop	No , Yes
	Determines whether the machine stops printing after the cartridge counter reaches the limit set with SP 3922.	

3924	Toner end sensor	
3924 1	Toner near-end	[100 ~ 1000 / 200 / 100 ms step] DFU
	Threshold adjustment for toner near-end detection.	
3924 2	Toner end	[250 ~ 1050 / 550 / 100 ms step] DFU
	Threshold adjustment for toner end detection	

3925	Cartridge info	
3925 1	Machine ID	Displays the model name stored in the toner cartridge IC chip.
3925 2	Version	Displays the cartridge version number stored in the toner cartridge IC chip.
3925 3	Brand ID	Displays the OEM brand name stored in the toner cartridge IC chip.
3925 4	Color ID	Displays the cartridge color name stored in the toner cartridge IC chip.
3925 5	Area ID	Displays the region stored in the toner cartridge IC chip.
3925 6	Kind ID	Displays the part code number stored in the toner cartridge IC chip.
3925 7	Secu ID	Displays the cartridge type ID stored in the toner cartridge IC chip.
3925 8	Maker ID	Displays the maker ID number stored in the toner cartridge IC chip.

SP5-xxx: Mode

5024	mm/inch Display Selection	0: Europe/Asia (mm), 1: North America (inch)
	Selects the unit of measurement. After selection, turn the main power switch off and on.	

5046	ROM Update Disp	Enables or disables the ROM Update utility. When enabled, this utility will be displayed in the user program mode. DFU [0 or 1 / 1 / -] • 0: Enabled 1: Disabled
-------------	-----------------	---

5104	A3/11x17 Count	Specifies whether the counter is doubled for A3/11" x 17" paper. If "Yes" is selected, the total counter counts up twice when A3/11" x 17" paper is used. Yes (double count) No (single count)
-------------	----------------	---

5305	Auto Off Set	Switches energy saver mode on/off Enable , Disable Enable: Energy saver mode will be used Disable: Energy saver mode will be ignored
-------------	--------------	--

5401	U limit auto select	Yes , No
	Determines whether the machine adds new user codes in the User Management Tool in Smart Net Monitor.	

5801	Memory Clear	Resets software counters and returns modes and settings to their defaults. All clear: Clears all data Engine clear: Clears the printer engine settings SCS: Clears the systems settings PRT: Clears user mode system settings NCS: Network control systems - Clears the items listed in the "Host Interface" section of the Configuration page. DCS: Delivery control system (e-mail settings) MIRS: E-mail addresses
	5801 1	Memory all clear
5801 2	Engine memory clear	Resets the following user tool settings: Maintenance menu: Main scan registration, sub scan registration, image density, curl control Resets the settings of the following SPs: 1003, 1104, 1105, 1902, 1910, 2001, 2112, 2113, 2201, 2213, 2301, 2910, 3921, 3922, 3923, 3924, 5930

5801 3	SCS memory clear Resets the following user tool settings: Paper Input menu: Paper type, paper size, tray lock, System menu: Energy saver timer Resets the settings of the following SPs: 5009, 5812 Also resets the user code counters.
5801 8	PRT memory clear Resets the following user tool settings: Paper Input menu: Tray priority System menu: Misfeed recovery, print error report, auto continue, memory overflow, output tray, job separation, memory usage
5801 11	NCS memory clear Resets the network settings, such as IP address and subnet mask
5801 14	DCS setting Resets the e-mail settings, such as those stored in SP 5860
5801 16	MIRS setting Resets the settings used for the e-mail alert feature (such as the enable/disable setting and the address used for the e-mail alert)

5802	Free run
	The machine performs a free run. Press [Enter] to start. Press [Enter] to stop. Please note that the machine will not stop immediately after the [Enter] key is pressed.

5803	Input check	
	Displays signals received from sensors and switches. NOTE: SP Modes other than those listed in this table, are not used in the machine.	
	Operation Panel	Component Name
5803 1	Front Door	Front cover safety switch
5803 2	MainMotLock	Main Motor Lock
5803 3	PolygonLock	Polygon Motor Lock
5803 5	Duplex door	Duplex Unit cover switch
5803 6	Duplex set	Duplex Unit
5803 7	Fusing set	Fusing Unit
5803 11	StdTrayFul	Paper Overflow Sensor
5803 16	Regist	Registration Sensor
5803 17	Pap Output	Paper Exit Sensor
5803 18	Dup in/out	Duplex Inverter Sensor
5803 19	Dup In	Duplex Entrance Sensor
5803 20	Duplex Out	Duplex Exit Sensor
5803 21	PinBypass	Bypass paper sensor
5803 22	NoT1paper	Paper end sensor-Standard Paper Tray Unit
5803 23	Tray1 Size	Paper size switch-Standard tray
5803 24	T1 Remains	Remaining paper sensor-Standard tray
5803 26	No T2 paper	Paper end sensor-1st Optional Paper Tray Unit
5803 29	No T3 paper	Paper end sensor-2nd Optional Paper Tray Unit
5803 30	Tray 3 Size	Paper size switch-2nd Optional Paper Tray Unit

5803	Input check	
	Displays signals received from sensors and switches. NOTE: SP Modes other than those listed in this table, are not used in the machine.	
	Operation Panel	Component Name
5803 31	T3 remains	Remaining paper sensor-2nd Optional Paper Tray Unit
5803 32	Carrier 2	Paper feed sensor-1st Optional Paper Tray Unit
5803 33	Carrier 3	Paper feed sensor-2nd Optional Paper Tray Unit
5803 34	Tray 2 size	Paper size switch-1st Optional Paper Tray Unit
5803 36	Tray2 Remains	Remaining paper sensor-1st Optional Paper Tray Unit
5803 41	Exit Door	Paper output tray cover sensor
5803 42	Sft Carrier	Shift tray paper transport sensor
5803 43	Sft to R	Shift tray at right
5803 44	Sft to L	Shift tray at left
5803 45	PaperinB1	Paper sensor - 1st bin
5803 46	Bin1 Full	Paper overflow sensor- 1st bin
5803 47	PaperinB2	Paper sensor - 2nd bin
5803 48	Bin2 Full	Paper overflow sensor- 2nd bin
5803 49	PaperinB3	Paper sensor - 3rd bin
5803 50	Bin3 Full	Paper overflow sensor – 3 rd bin
5803 51	PaperinB4	Paper sensor - 4th bin
5803 52	Bin4 Full	Paper overflow sensor – 4th bin
5803 53	4bin Up Tr	Upper paper transport sensor - Mailbox
5803 54	4bin Lwr Tr	Lower paper transport sensor - Mailbox

5804	Output check	
	Turns on electrical components individually for test purposes. NOTE: SP Modes other than those listed in this table, are not used in the machine.	
	Operation Panel	Component Name
5804 0	Impossible	Not used in this machine
5804 1	Main Motor	Main Motor
5804 2	Carr Clutch	Relay Clutch
5804 3	Reg Clutch	Registration Clutch
5804 5	Tray1 Clutch	Paper Feed Clutch
5804 6	Byp Clutch	Bypass Feed Solenoid
5804 11	Fan/speedy	Exhaust fan
5804 12	Fan/slowly	Exhaust fan
5804 13	Fus Relay	Fusing Lamp Relay
5804 22	Pol Motor	Polygon Motor
5804 23	Pol + LD	Polygon Motor and Laser Diode
5804 26	T2 Clutch	Paper Feed Clutch-1st Optional Paper Tray Unit
5804 27	T2 Motor	Paper Tray Motor-1st Optional Paper Tray Unit
5804 28	T3 Clutch	Paper Feed Clutch-2nd Optional Paper Tray Unit

5804 29	T3 Motor	Paper Tray Motor-2nd Optional Paper Tray Unit
5804 31	Exit motor.	Paper exit motor (1-bin shift tray, 4-bin mailbox)
5804 32	Exit solenoid.	Paper exit junction gate solenoid
5804 33	Motor to R.	1-bin shift tray - right
5804 34	Motor to L.	1-bin shift tray - left
5804 35	SP1 solenoid.	Mailbox turn gate solenoid 2
5804 36	SP2 solenoid.	Mailbox turn gate solenoid 3
5804 37	SP3 solenoid.	Mailbox turn gate solenoid 4
5804 41	Dup Side Rt.	Duplex Inverter Motor-forward
5804 42	Dup Side Rv	Duplex Inverter Motor-reverse
5804 43	Dup Long	Duplex Transport Motor
5804 44	Dup Split	Inverter Gate Solenoid

5810	Fusing err clear
	Resets a service call condition (for fusing unit errors). After using this SP mode, turn the main switch off and on.

5811	Serial Number DFU
	Used to input the machine serial number. This is normally done at the factory. <i>If you want to know the serial number, print the system parameter list. Press  and then input "A".</i>

5812	Service Tel. No. Setting	
	Use these SP modes to input service and support telephone numbers. Enter the number and press <i>Press the  key to input a pause. Press the "Clear modes" key to delete the telephone number.</i>	
5812 1	Tel No.	Use this to input the telephone number of the CE printed on the SP print mode printout.
5812 2	Fax	Use this to input the fax number of the CE printed on the SP print mode printout.

5828	Network	
5828 71	Primacy I/F	DFU
5828 72	Current I/F	Displays what type of network is being used.
5828 111	Login mode (NW)	Determines which method the printer is installed in a Netware environment. 0: File server 1: NDS tree
5828 112	NDS Tree Name (NW)	Displays the tree name

5832	HDD Init
	Initializes the hard disk. Use this only if there is a hard disk error.

5837	Prog checksum
	Displays the checksum for the engine firmware.

5839	IEEE1394: Not used
	Do not change the setting.

5840	IEEE802.11b: Not used
	Do not change the setting.

5844	USB	
5844 1	Transfer rate	FS Fixation: Full Speed (Fixed) HS/FS Auto: High Speed/Full Speed (Automatic change)
	Sets the speed for USB data transmission.	
5844 2	Vendor ID	DFU
5844 3	Product ID	DFU
5844 4	Dev release number	DFU

5845	Delivery Server Setting	
	Provides items for delivery server settings.	
5845 3	Retry Interval	[60~900 / 300 / 1]
	Determines the time interval between retries before the machine returns to standby after an error occurs during an image transfer with the delivery scanner or SMTP server.	
5845 4	Number of Retries	[0~99 / 3 / 1]
	Determines the number of retries before the machine returns to standby after an error occurs during an image transfer with the delivery or SMTP server.	

5851	Bluetooth: Not used
	Do not change the setting.

5856	Remote Program Update: Local port. (☛ 5.5)
	When set to “enable” allows reception of firmware data via the local port (IEEE 1284) during a remote ROM update. Disable, Enable <i>This setting is reset to “disable” after the machine is cycled off and on</i>

Service Tables

5857	Save Debug Log: Not used
Do not change the setting.	

5858	Debug Log Save Function: Not used
Do not change the setting.	

5859	Debug Log Save Key No.: Not used
Do not change the setting.	

5860	SMTP/POP3/IMAP	
5860 2	SMTP ser port no.	Input the SMTP server port number
5860 3	SMTP auth	SMTP authentication enable/disable
5860 6	SMTP auth encryp	Encryption mode for SMTP authentication enable/disable (Only valid if 5860 3 is set to "enable")
5860 7	POP before SMTP	Enable/disable POP before SMTP. If the SMTP server does not have authentication, you can enable POP before SMTP, then POP authentication is available (SP 5860 13)
5860 8	POP to SMTP wait	When using POP before SMTP, this SP mode determines the maximum wait time between POP authentication and connection with SMTP. Communication stops if this time is exceeded.
5860 13	POP auth encryp	If POP before SMTP is enabled, then you can use this SP to enable or disable encryption mode for POP authentication
5860 14	POP serv port no.	Input the POP server port number
5860 22	SMTP from replace	If SMTP authentication is enabled, this SP mode determines which name is included in the e-mail header 0: Normal sender name 1: User name used by the authentication feature

5866	E-mail alert	0: Date not added to mail header 1: Date added to mail header
-------------	--------------	--

5869	RAM disk setting	DFU
-------------	------------------	------------

5902	Test print	
	Prints the test pattern that you selected with SP 2902.	
5902 1	1 sheet test	
	Prints one copy of the test pattern	
5902 2	Cont test	
	Prints consecutive copies of the test pattern	

5907	Plug & Play	
	Sets the brand name and the production name for Windows Plug & Play. This information is stored in NVRAM. If the NVRAM is defective or has been replaced, these names should be registered again. <i>To set the plug and play model name, enter the model number, and then press #.</i>	

5930	Meter charge mode	No, Yes
	Enables or disables meter-charge mode. Important: Turn the main switch off/on after changing this setting. Meter charge mode enabled: <ul style="list-style-type: none"> • “Replace Maintenance Kit” is not displayed on the operation panel when the PM counter runs out (the technician replaces the maintenance kit items) • The meter charge counter is shown immediately after the Menu key is pressed. • The technician must reset the PM counter after finishing PM. Meter charge mode disabled: <ul style="list-style-type: none"> • “Replace Maintenance Kit” is displayed on the operation panel when the PM counter runs out (the user replaces the maintenance kit items) • The meter charge counter is not shown when the Menu key is pressed. • The PM counter resets automatically after the user replaces the fusing unit. 	

5970	Debug Serial Output	DFU
-------------	---------------------	------------

5990	SP print mode		
	5990 2	SP (Mode Data List)	Prints summary sheet for the item selected.
	5990 7	NIB Summary	

Service Tables

SP7-xxx: Data Log

7001	Operation time
	Displays the total number of engine rotation cycles made so far. Note: One cycle is calculated as 3.9 s of drum rotation. However, this counter also includes idle rotations. This counter is not reset at PM.

7003	Total counter
	Displays the controller total counter. This counter is used for meter charge, and it appears when the user presses the Menu key (if meter charge mode is enabled). It does not count up when certain items, such as service reports, are printed (see section 6.6.1. for a complete list of conditions).

7801	ROM version display
	Displays the firmware version (system, engine, and duplex).
7803 1	System Version
7803 2	Engine Version
7803 3	Duplex Version

7803	PM Counter
	Displays the PM counter. This is not a page counter. It estimates the page count using the engine rotation cycle count. It counts up one page when the engine has made the average number of rotations that is required for one page of a three-page job.
7803 1	Transfer roller
7803 2	Paper feed roller
7803 3	Fusing unit

7804	PM counter reset
	Resets the PM counter. Important: If a technician replaces the PM items, reset this counter after replacing these items.
7804 1	Transfer roller
7804 2	Paper feed roller
7804 3	Fusing unit

7832	Diag Result
	Press # to display a list of error codes. Nothing is displayed if no errors have occurred.

7901	Assert Info DFU (Used for debugging.)	
7901 1	Assert Info	DFU
7901 2	# of Lines	DFU
7901 3	Location	DFU

7993	Total counter	
	Displays the engine total counter. It counts up for all prints, including service reports.	

SP8-xxx: Counters

8064	P: 1-0-07	P: FIN Jobs
8064 7	Others	

8067	O: 1-0-07	O: FIN Jobs
8067 7	Others	

8381	T: 2-2-01	T:AplOut/PGS
8381 1		

8384	P: 2-2-01	P:AplOut/PGS
8284 1		

8387	O: 2-2-01	O:AplOut/PGS
8387 1		

8391	T: 2-2-01	LrgSize Out/PGS
8391 1	A2	

8411	T: 2-2-04	DupOut/Sheets
8411 1		

8421	T: 2-2-05	T: Dup nUp OutPGS
	Mechanical Counter by Print Mode	
8421 1	Simplex> Duplex	Counts pages
8421 4	Simplex Combine	Combine pages
8421 5	Duplex Combine	Combine pages
8421 6	2>	Combines 2 in 1
8421 7	4>	Combines 4 in 1
8421 8	6>	Combines 6 in 1
8421 9	8>	Combines 8 in 1
8421 10	9>	Combines 9 in 1
8421 11	16>	Combines 16 in 1
8421 12	Booklet	Prints books
8421 13	Magazine	Prints magazines

8424	P: 2-2-05	P: Dup nUP OutPGS
	Controller Counter by Print Mode	
8424 1	Simplex>Duplex	Counts pages
8424 4	Simplex Combine	Counts pages
8424 5	Duplex Combine	Counts pages
8424 6	2>	Combine pages
8424 7	4>	Combine pages
8424 8	6>	Combines 2 in 1
8424 9	8>	Combines 4 in 1
8424 10	9>	Combines 6 in 1
8424 11	16>	Combines 16 in 1
8424 12	Booklet	Prints books
8424 13	Magazine	Prints magazines

8427	O: 2-2-05	O: Dup nUP OutPGS
	Others by Print Mode	
8427 1	Simplex> Duplex	Counts pages
8427 4	Simplex Combine	Combine pages
8427 5	Duplex Combine	Combine pages
8427 6	2>	Combines 2 in 1
8427 7	4>	Combines 4 in 1
8427 8	6>	Combines 6 in 1
8427 9	8>	Combines 8 in 1
8427 10	9>	Combines 9 in 1
8427 11	16>	Combines 16 in 1
8427 12	Booklet	Prints books
8427 13	Magazine	Prints magazines

8441	T: 2-2-07	T: Copy Size/PGS
	Mechanical Total Counter by Page Size	
8441 1	A3	
8441 2	A4	
8441 3	A5	
844 1 4	B4	
8441 5	B5	
8441 6	DLT	
8441 7	LG	
8441 8	LT	
8441 9	HLT	
8441 10	12 x 18/ 13 x 19	
8441 254	Others: Fixed	
8441 255	Others: Custom	

8444	P: 2-2-07	P: Copy Size/PGS
	Controller Count by Page Size	
8444 1	A3	
8444 2	A4	
8444 3	A5	
8444 4	B4	
8444 5	B5	
8444 6	DLT	
8444 7	LG	
8444 8	LT	
8444 9	HLT	
8444 10	12 x 18/ 13 x 19	
8444 254	Others: Fixed	
8444 255	Others: Custom	

8447	O: 2-2-07	O: Copy Size/PGS
	Others Count by Page Size	
8447 1	A3	
8447 2	A4	
8447 3	A5	
8447 4	B4	
8447 5	B5	
8447 6	DLT	
8447 7	LG	
8447 8	LT	
8447 9	HLT	
8447 10	12 x 18/ 13 x 19	
8447 254	Others: Fixed	
8447 255	Others: Custom	

8451	2-2-08	Feed Tray Sheets
	Counter by Tray	
8451 1	Bypass Tray	
8451 2	Standard Tray	
8451 3	1st optional tray	
8451 4	2nd optional tray	
8451 5	Not used in this machine	
8451 6	Not used in this machine	
8451 7	Not used in this machine	
8451 8	Not used in this machine	
8451 0	Not used in this machine	

Service Tables

8461	T: 2-2-09	T:Paper Type
	Counter by Paper Type	
8461 1	Normal	
8461 2	Recycled	
8461 3	Special	
8461 4	Thick	
8461 5	Normal (Front)	
8461 6	Thick (Back)	
8461 7	OHP	
8461 8	Other	

8464	P: 2-2-09	T: Paper Type
	Controller Counter by Paper Type	
8464 1	Normal	
8464 2	Recycled	
8464 3	Special	
8464 4	Thick	
8464 5	Normal (Front)	
8464 6	Thick (Back)	
8464 7	OHP	
8464 8	Other	

8521	T: 2-2-15	T:FIN Proc/PGS
	Total Edit by Print Mode	
8521 7	Others	

8524	P: 2-2-15	P: FIN Proc/PGS
	Total Controller Edit by Print Mode	
8524 1-6	Not used in this machine	
8524 7	Others	

8581	T: Admin Counter	
	Total Counter	
8581 1	Total	

8591	O: 2-2-23	O: Admin Counter
	Total Counter	
8591 1	A3/DLT	
8591 2	Duplex Counter	
8591 3	Not used in this machine	

8771	3-0-01	DevelCnt/PGS
	Total Development Counter	
8771 1	Total	

8801	3-0-05	Toner Remain
	Toner Counter	
8801 1	Bk	

8941	3-6-01	MachStatus Time
	Checks the Machine Status	
8941 1	Operation time	
8941 2	Stand-by time	
8941 3	Energy Saver time	
8941 4	Sleep mode	
8941 5	Off mode time	
8941 6	Downtime/SC	
8941 7	Downtime/Printer Jam	
8941 8	Downtime/Scn Jam	
8941 9	Downtime/Toner End	

5.4 UPDATING THE FIRMWARE

⚠ CAUTION
Do not turn off the machine while downloading the firmware.

5.4.1 CONTROLLER FIRMWARE

NOTE: 1) Turn the machine off before starting the firmware update procedure.
 2) Controller/NIB firmware includes the following firmware types:

- * Card 0: Platform & Rescue
- * Card 1: Printer
- * Card 2: Web Support

Use the cards in numerical order starting from card 0, then card 1 and then card 2

1. Prepare a card that contains the required firmware.
2. Turn off the power and remove the cover [A] (1 screw).
3. Insert the card [B] into the card slot [C] and turn on the power.
4. Push the "Online Key" when "Platform and Rescue" is displayed (in the case of card 0).

NOTE: Card 1 will display "Printer" and card 2 will display "Web Support".

5. The firmware download is finished when "Updated" is displayed.
6. After the firmware download has finished, turn off the power and remove the card.
7. Repeat step 3 to 6 for the remaining firmware cards.
8. After the firmware download has finished, turn off the power and remove the card. Then replace the cover [A].
9. Turn on the power, and print the service summary report to confirm that the new firmware version has been installed.

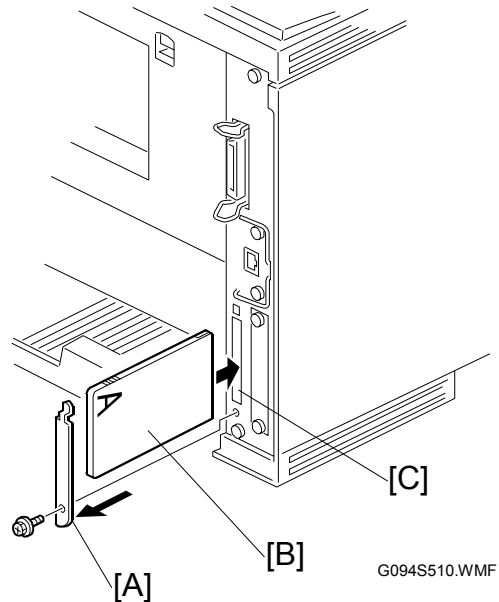

5.4.2 ENGINE FIRMWARE

NOTE: There is only one Engine Firmware card.

1. Prepare a card that contains the required firmware.
2. Turn off the power and remove the cover [A] (1 screw).
3. Insert the card [B] into the card slot [C].
4. Open the front door and then turn on the power.
NOTE: Opening the front door during the engine firmware procedure prevents overheating in the fusing unit.
5. Push the “Online Key” when “Engine” is displayed.
6. The firmware download is finished when “Updated” is displayed.
7. After the firmware download has finished, turn off the power and remove the card.
8. Close the front door and then replace the cover [A].
9. Turn on the power, and print the service summary report to confirm that the new firmware version has been installed.

5.4.3 ERROR RECOVERY

Controller

If an error occurs during updating the controller firmware, use the following procedure. This procedure will force the controller to boot from the firmware card.

1. Prepare a card with the required controller firmware version.
2. Turn off the machine and remove the controller.
3. Change the DIP Switch 2 - No. 1 setting to "ON".

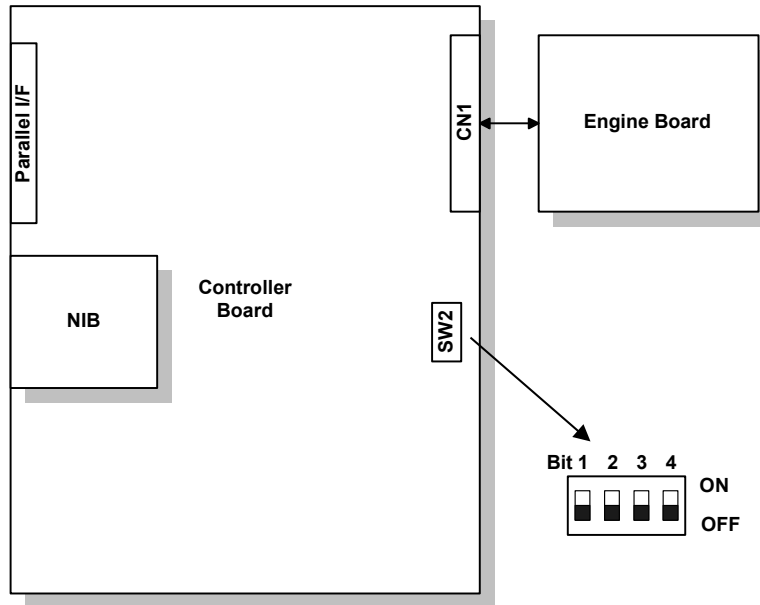

G094S504.WMF

4. Put back the controller
5. Insert the card into the card slot on the controller.
NOTE: When you see the machine from the back, the "A" side of the card must face the right.
6. Turn on the machine. The machine automatically starts to download the software.
7. When downloading is finished, "Updated" is displayed.
8. Turn off the machine. Then remove the card.
9. Reset the DIP Switch 2 - No.1 setting to "OFF" and then put back the controller.
NOTE: 1) You must perform steps 5 to 8 for all three firmware cards.
2) The default settings of the DIP Switches are all "OFF".
10. Turn on the machine, and print the service summary report.

Engine

If a download attempt failed, try downloading the new firmware again using the normal firmware download procedure described in section 5.4.2.

5.5 REMOTE FIRMWARE UPDATE (RFU)

Refer to the general RTB for the RFU procedure.

- NOTE:** 1) Before you do the RFU procedure the machine must be in the Frame Priority setting. This can be set in the memory priority function of the system menu of the user tools. The reason for this is the Frame Priority setting uses less of the installed system memory than the Font Priority setting.
- 2) You cannot do the RFU if the machine is set to the Font Priority.

5.6 LOOP-BACK TEST

This self-diagnostic test requires a loop-back connector (P/N: G0219350).

1. Turn off the machine and attach the loop-back connector to the parallel interface.
2. Turn on the machine while pressing the “On Line” key and “# Enter” key together.
3. The machine prints the diagnostic report automatically.
 - To check the error codes, use engine SP mode 7832.
 - Refer to section 4.2 for details about the error codes.

5.7 POWER-ON SELF TESTS

The controller tests the following devices at power-on. If an error is detected, an error code is stored in the controller board.

- CPU, ASIC and clock
 - Flash ROM
 - Resident and optional SDRAM
 - Parallel interface
 - NIB
 - NVRAM
 - Optional HDD (if installed)
-
- To check the error codes, use engine SP mode 7832.
 - Refer to section 4.2 for details about the error codes.

5.8 USER PROGRAM MODES

Press the “Menu” button and use the “Up/Down arrow” keys to scroll through the menu listing. To go back to a higher level, press the “Escape” key. After changing the settings, press the “On Line” key. The user menu list can be printed using “Menu List” in the “List/Test Print” user mode.

User Mode Tree

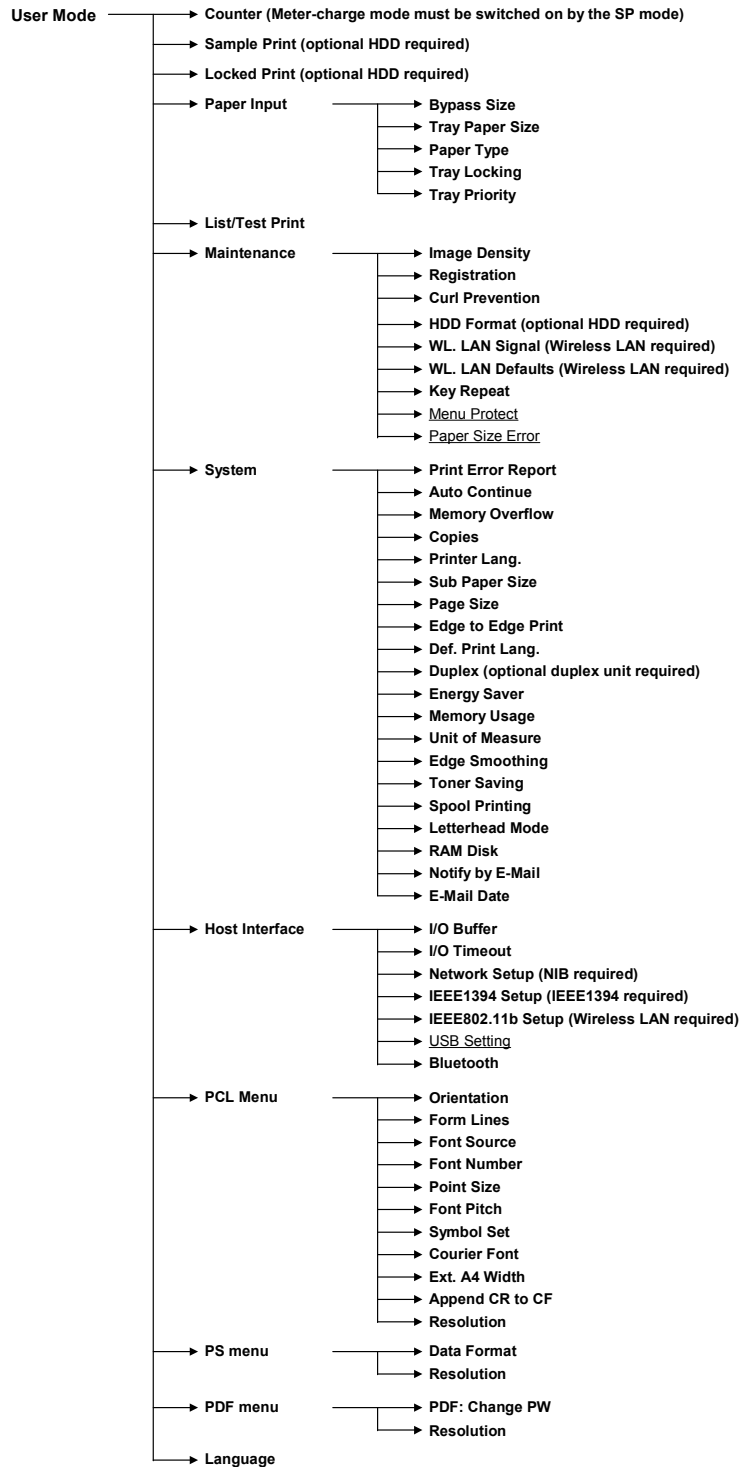

G094S511.WMF

5.9 DIP SWITCHES

Controller Board

DIP Switch 2 (Bit 1) on the controller is used for error recovery after a firmware updating procedure failed.

NOTE: The default settings of the DIP Switches are all “OFF”.

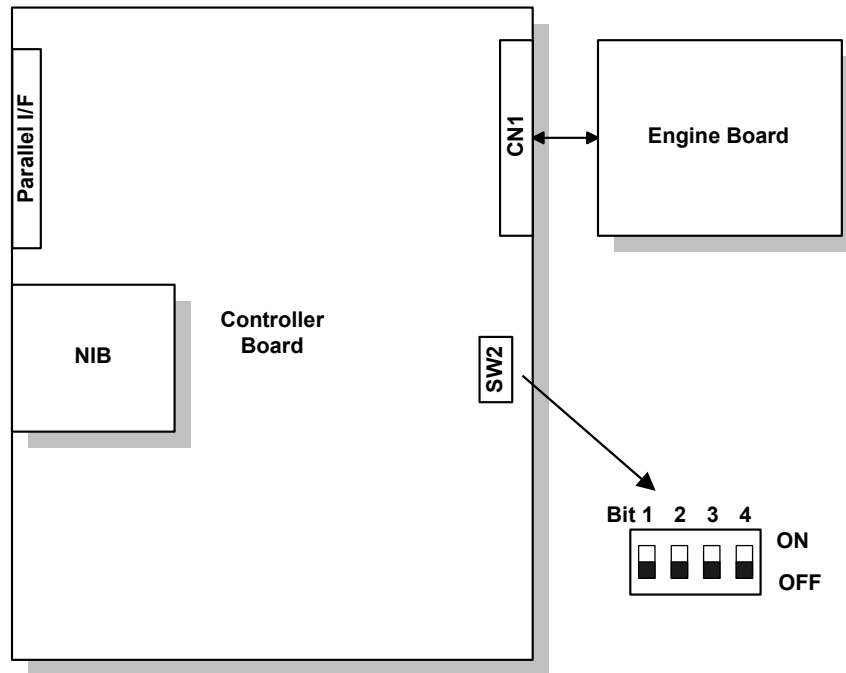

G094S504.WMF

Service
Tables

6. DETAILED SECTION DESCRIPTIONS

6.1 OVERVIEW

The descriptions in this section are for the G091 China model machine.

6.1.1 MECHANICAL COMPONENT LAYOUT

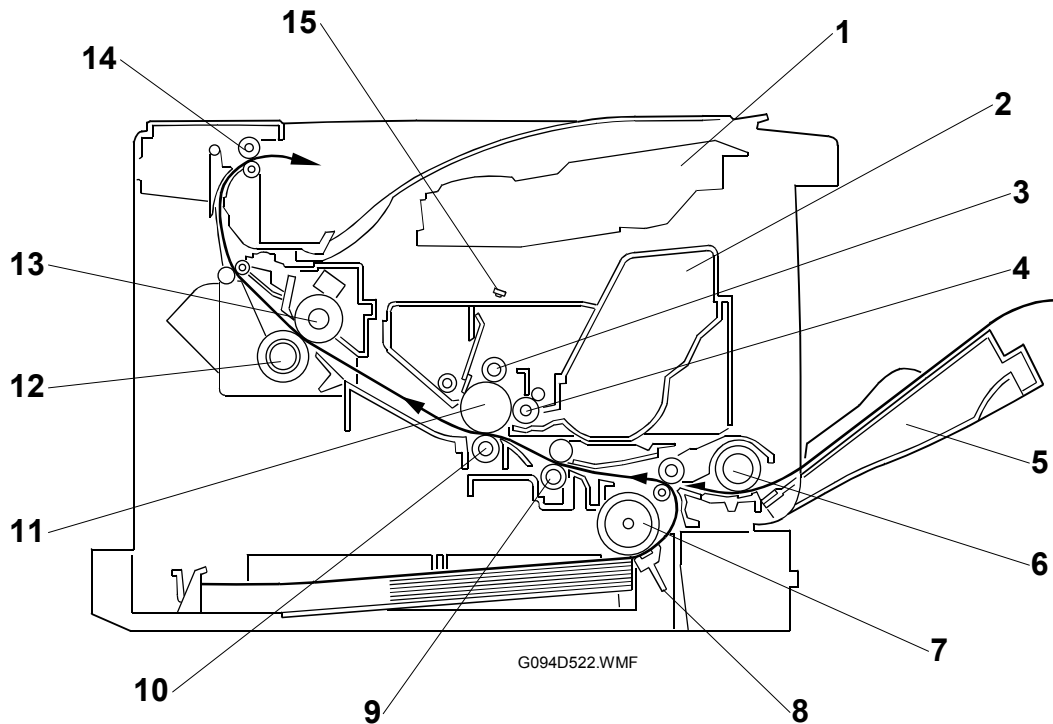

- | | |
|-------------------------|------------------------|
| 1. Laser unit | 9. Registration roller |
| 2. Cartridge (AIO-type) | 10. Transfer roller |
| 3. Charge roller | 11. Drum |
| 4. Development roller | 12. Pressure roller |
| 5. By-pass feed tray | 13. Hot roller |
| 6. By-pass feed roller | 14. Paper exit roller |
| 7. Paper feed roller | 15. Quenching lamp |
| 8. Friction pad | |

6.1.2 PAPER PATH

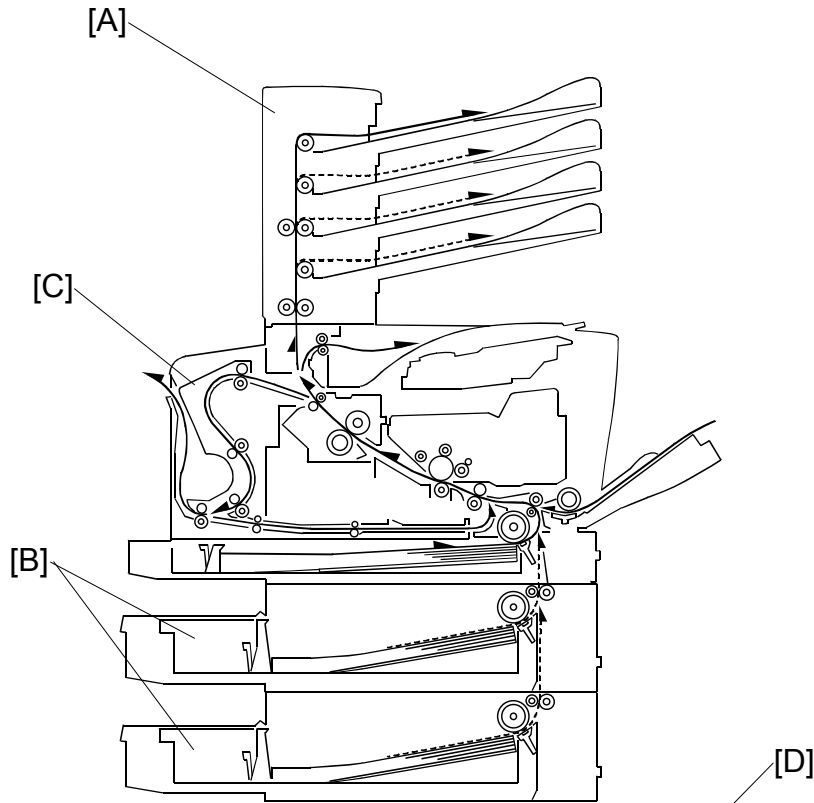

G091D109.WMF

- [A]: Optional four-bin mailbox
- [B]: Optional paper tray unit
- [C]: Optional duplex unit
- [D]: Optional one-bin shift tray unit

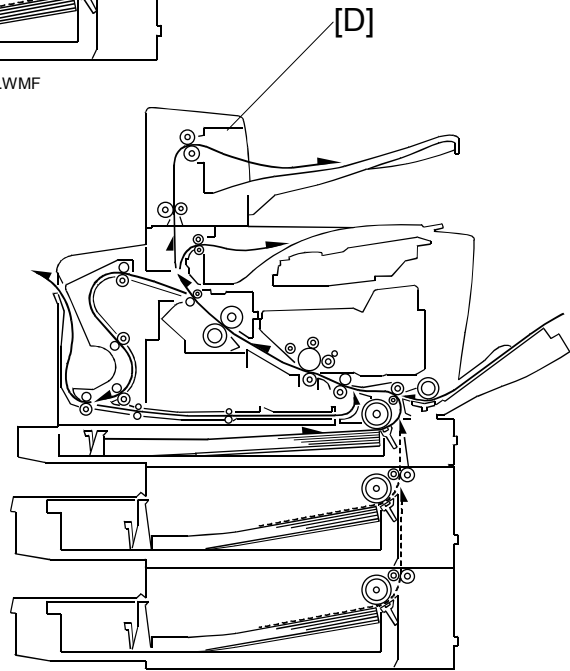

G091D110.WMF

6.2 BOARD STRUCTURE

6.2.1 BLOCK DIAGRAM

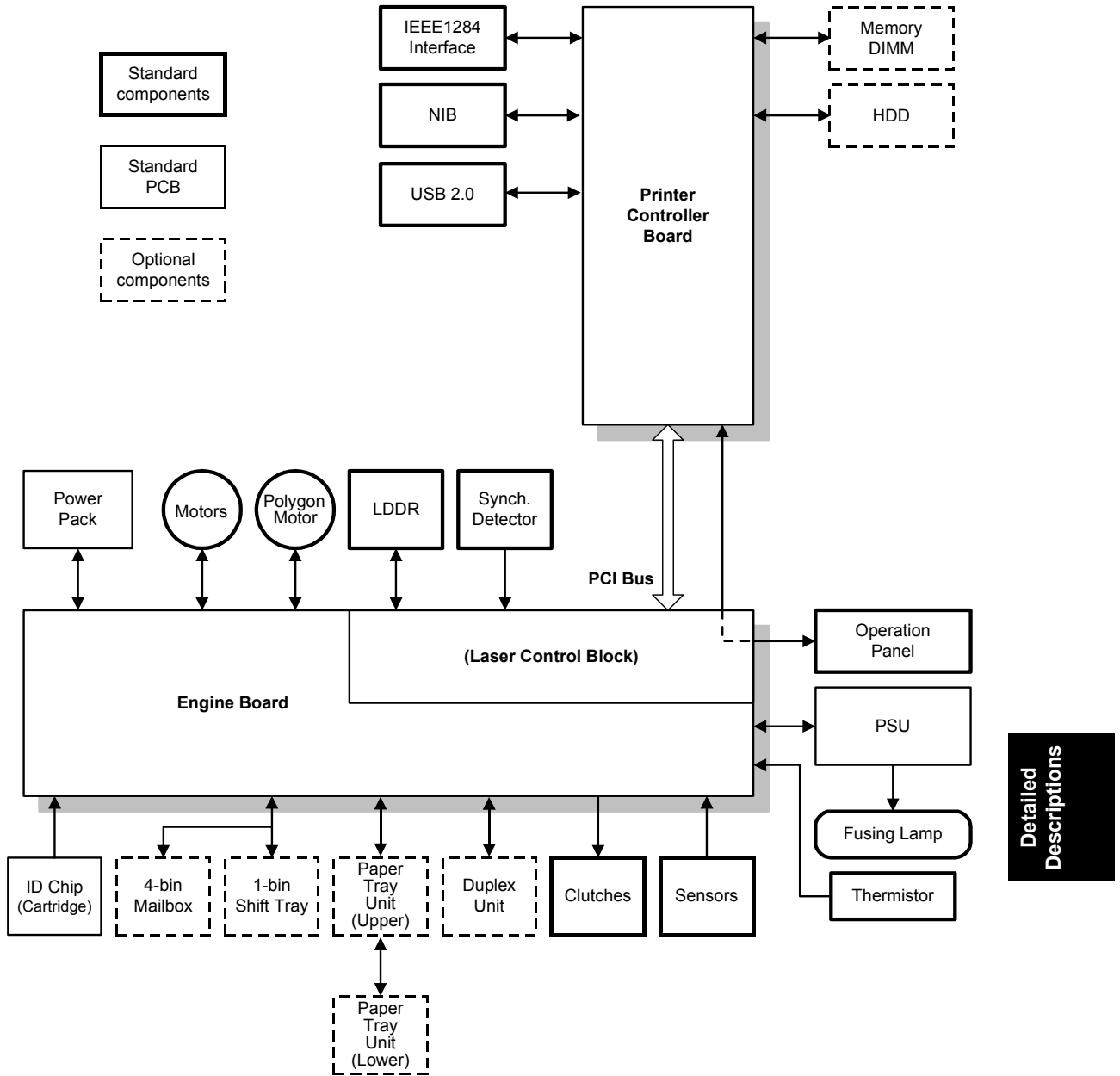

G091D910_CHN.WMF

The engine board controls all the mechanical components.

The printer controller board connects to the engine board through a PCI bus.

6.2.2 DESCRIPTIONS

1. Engine Board

The engine board controls these functions:

- Engine sequence
- Machine and printer engine operation
- Timing for external options
- High voltage supply, laser, and fusing
- Sensors, motors, and solenoids

2. Printer Controller Board

The printer controller board controls these functions:

- Printer-to-host interface
- Operation panel interface
- Interfacing and control of the NIB, printer interface boards, and other options (HDD and DRAM DIMM)

3. LDU

This controls the laser diodes.

4. Network Interface Board (NIB)

The network interface board connects the printer to a network.

5. HDD Unit (Option)

The HDD unit holds the data for these functions:

- More soft fonts
- Collation
- Locked print
- Sample print
- Downloading forms for form overlay

6. Memory DIMM (Option: 64MB/128MB/256MB DRAM)

This gives more memory for printer processing, collation, and for soft fonts.

7. Operation Panel Board

Controls the display panel, the LED, and the key pad.

8. Standard interface boards

The machine has these built-in printer interfaces:

- IEEE1284 (also known as Centronics or parallel port), USB, Ethernet

6.2.3 CONTROLLER BOARD

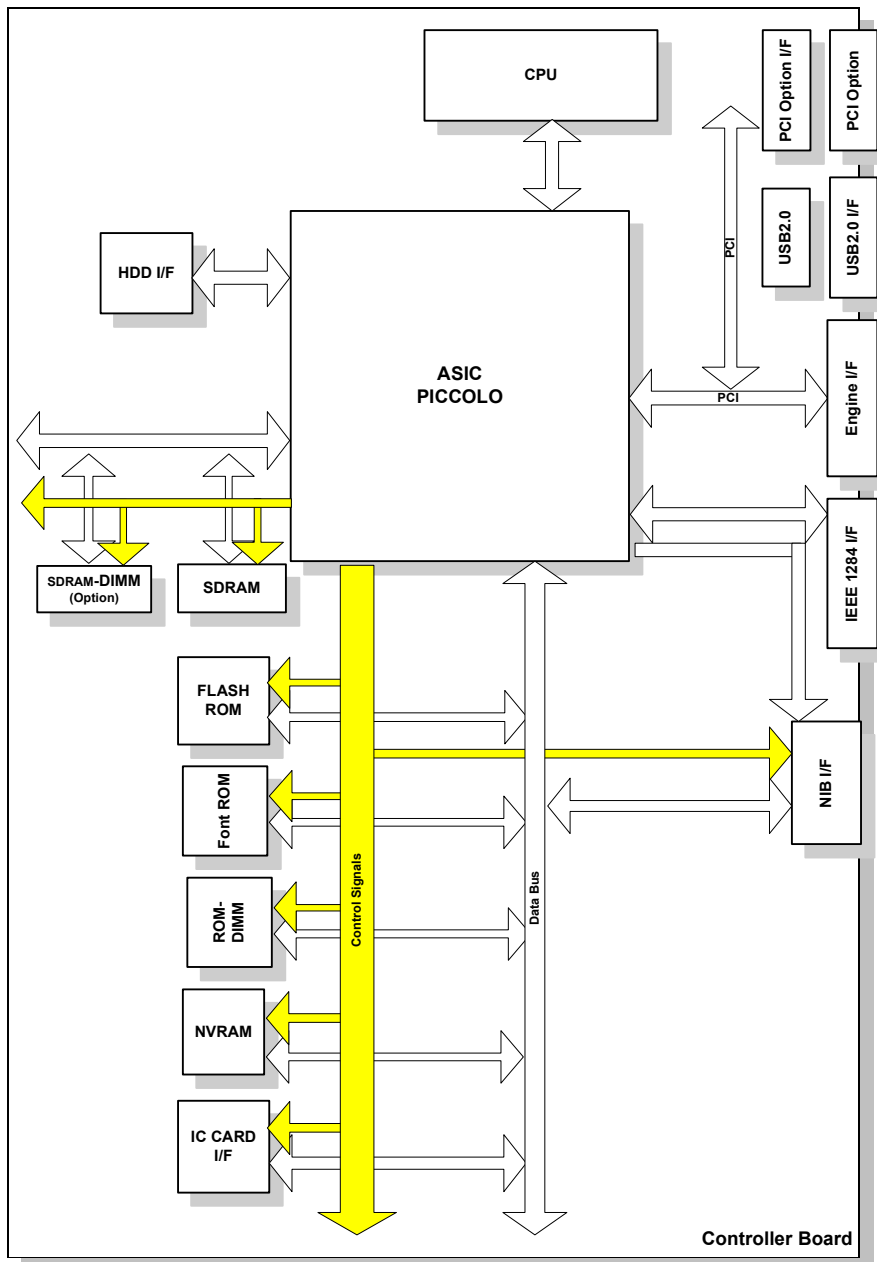

G091D909_CHN.WMF

Detailed Descriptions

PICCOLO	The PICCOLO ASIC controls all the functions of the printer controller board.
CPU	TX4955 300 Mhz
RAM	Resident: 64 MB SDRAM Option: 1 slot SDRAM DIMM (64/128/256 MB)
ROM	Flash: 16 MB ROM (Emulation) Mask: 4 MB (PCL/PS font)
NVRAM	Stores the controller settings
HDD	6 GB

6.3 PRINTING PROCESS

6.3.1 OVERVIEW

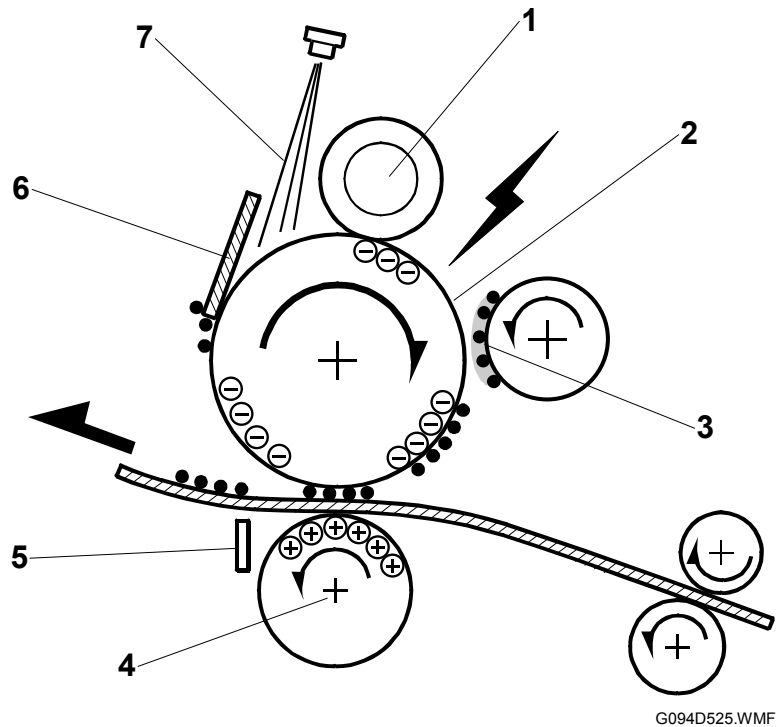

1. **Drum Charge:**
The charge roller gives the drum a negative charge.
2. **Laser Exposure:**
A laser beam writes the print data on the drum.
3. **Development:**
The development roller moves toner to the latent image on the drum surface.
4. **Image Transfer:**
The transfer roller moves the toner from the drum to the paper.
5. **Separation:**
The separation plate helps to remove the paper from the drum.
6. **Cleaning:**
The cleaning blade removes remaining toner on the drum surface after the image moved to the paper.
7. **Quenching:**
The light from the quenching lamp cancels the charge that stays on the drum.

6.3.2 LASER EXPOSURE

Overview

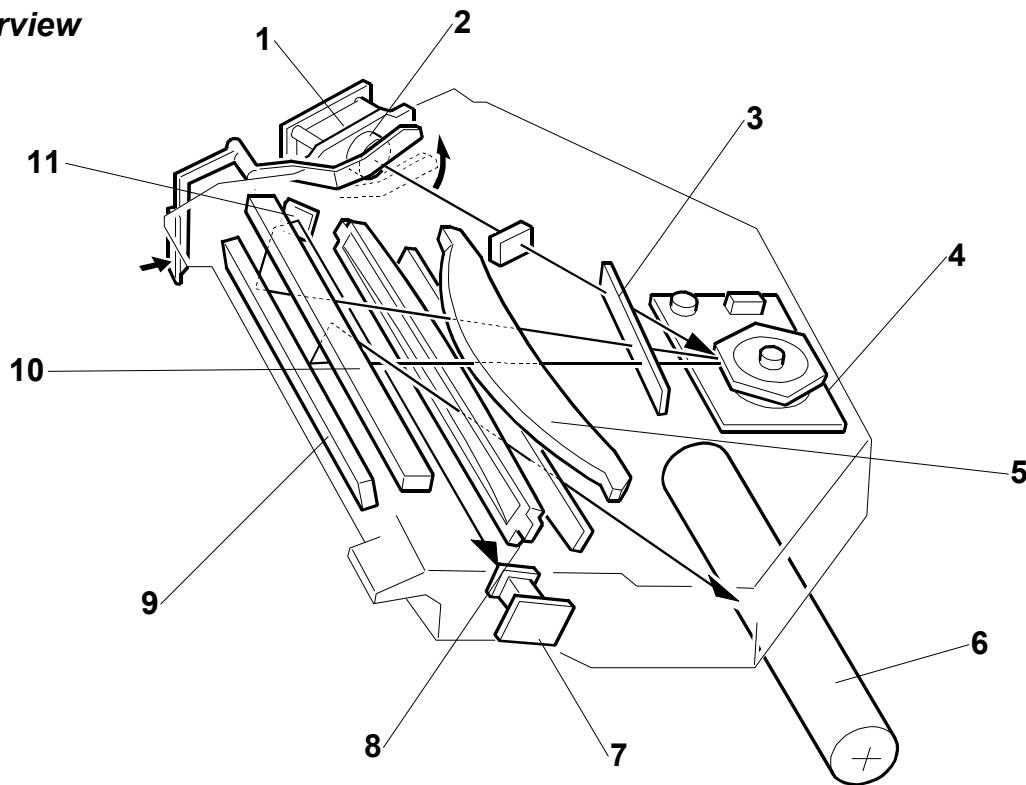

G094D526.WMF

- | | |
|-------------------|-----------------------------|
| 1. LD unit | 7. Synchronization detector |
| 2. Laser shutter | 8. Toroidal lens |
| 3. Shield glass | 9. 1st mirror |
| 4. Polygon mirror | 10. 2nd mirror |
| 5. F-Theta lens | 11. Detector mirror |
| 6. Drum | |

- Synchronization detector: The 1st mirror, 2nd mirror, and the detector mirror reflect the beam from the LD unit to the synchronization detector.
- Two laser beams: The LD unit writes two lines at the same time.
- LD safety shutter: When the user opens the front cover, the shutter closes and blocks the laser beam path.
- After you replace the LD unit, adjust its position (see Replacement and Adjustment).
- The thermistor next to the laser unit (not shown) checks the temperature inside the machine. The machine automatically corrects the charge roller and transfer voltages for this temperature.

Automatic Power Control (APC)

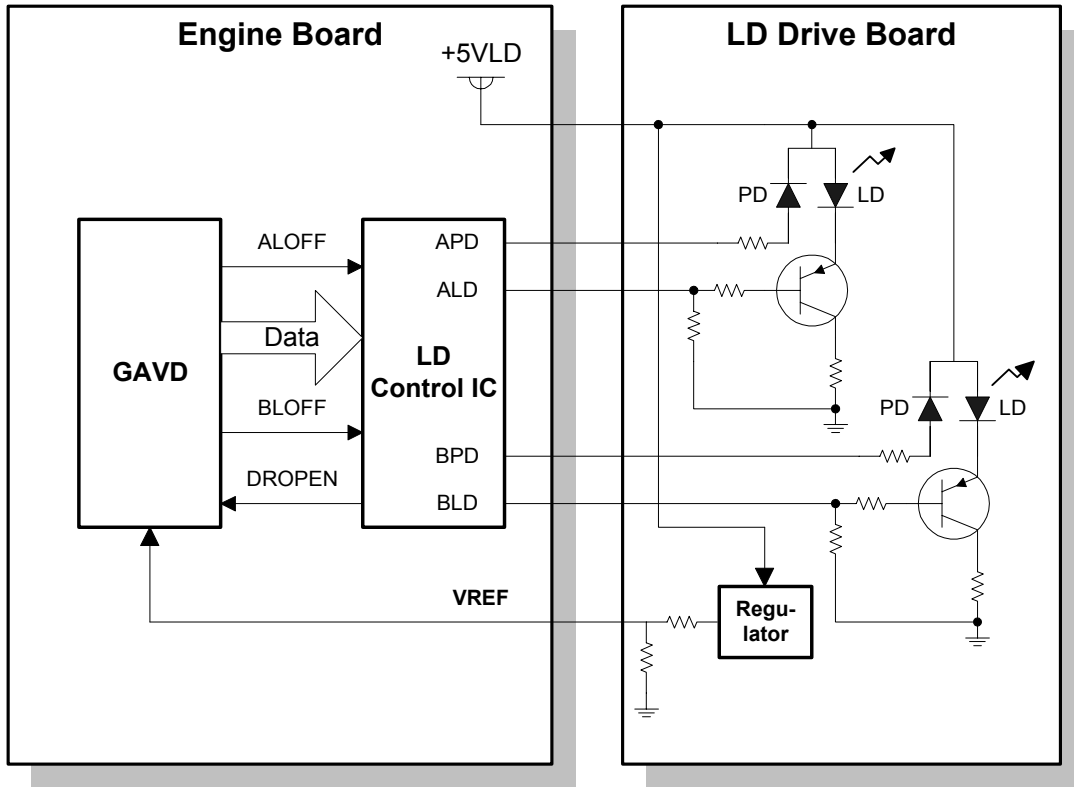

G094D527.WMF

The LD control IC on the engine board automatically controls power for the laser diodes. The laser diode power is adjusted in the factory.

NOTE: Do not touch the variable resistors on the LD unit in the field.

LD Safety Mechanisms

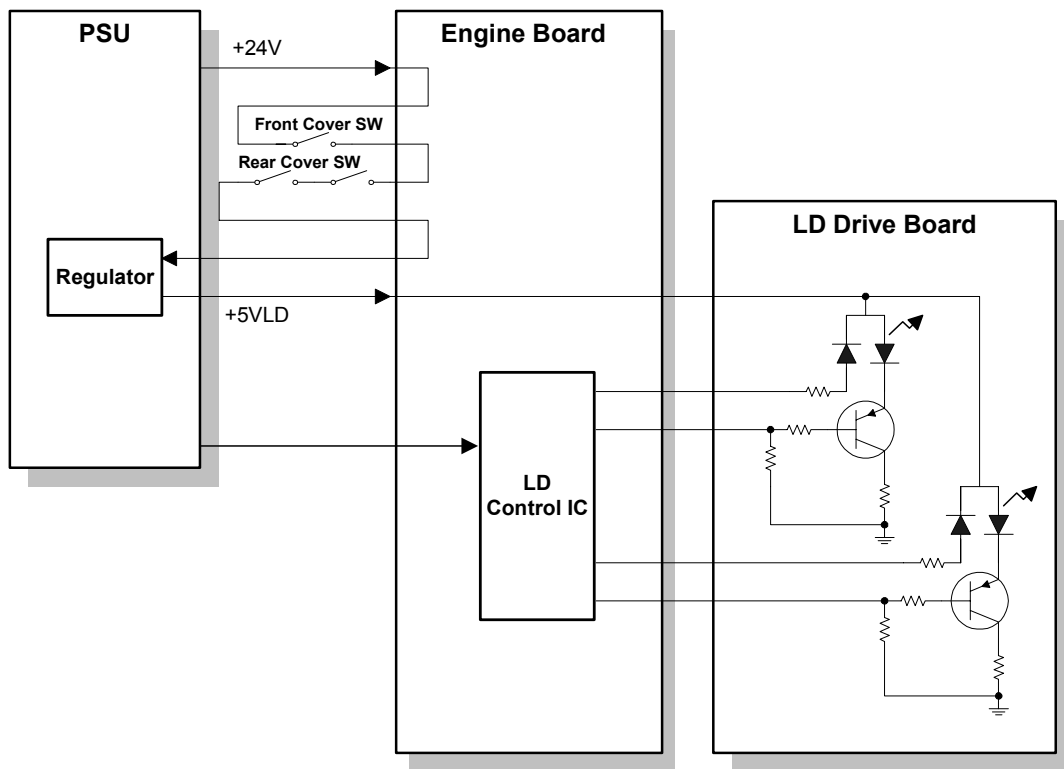

G094D528.WMF

Laser Safety Switch

There are safety switches on the front and rear covers. These switches stop the laser while the cover is open.

If the user opens one of these covers, the +5VLD power to the laser diodes is stopped.

Detailed Descriptions

Laser Shutter

The laser shutter [A] is for back-up safety. If the switches do not work, the +5VLD power gets to the laser diodes if the cover is open.

The laser shutter cuts the laser beam when the front cover is open.

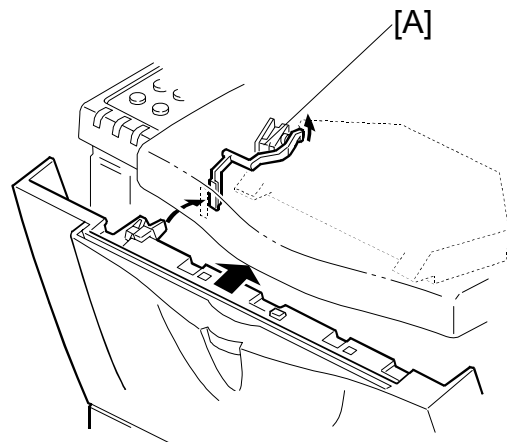

G094D529.WMF

6.3.3 CARTRIDGE OVERVIEW

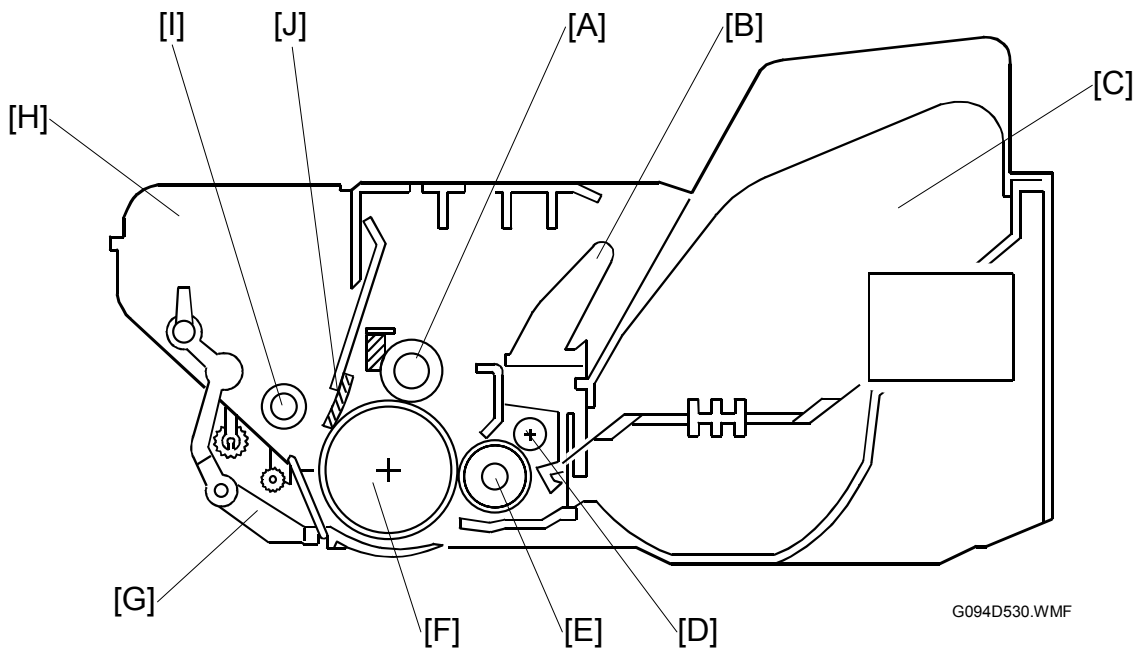

- | | |
|-------------------------|------------------------------|
| [A]: Charge roller | [F]: Drum |
| [B]: Developer tank | [G]: Drum shutter |
| [C]: Toner tank | [H]: Waste toner tank |
| [D]: Reverse roller | [I]: Toner collection roller |
| [E]: Development roller | [J]: Cleaning blade |

This type of cartridge is known as an “All-in One” (AIO) cartridge.

6.3.4 DRUM CHARGE

- [A]: Charge roller
- [B]: Cleaning pad

- The charge roller [A] gives the drum surface a negative charge of approximately -900 V .
- The cleaning pad [B] touches the charge roller to clean the surface.

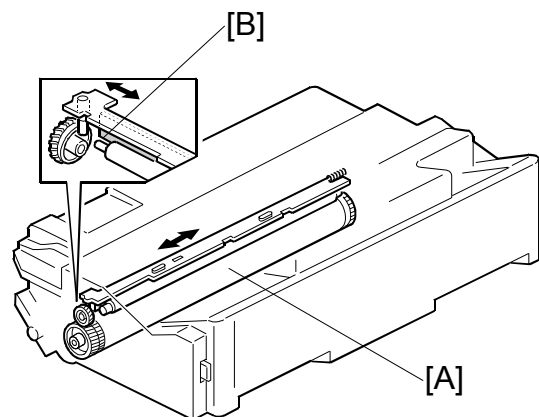

6.3.5 DEVELOPMENT

- [A]: Toner tank
- [B]: Agitator
- [C]: Pre-doctor blade
- [D]: Development roller
- [E]: Drum
- [F]: Doctor blade
- [G]: Reverse roller
- [H]: Developer tank

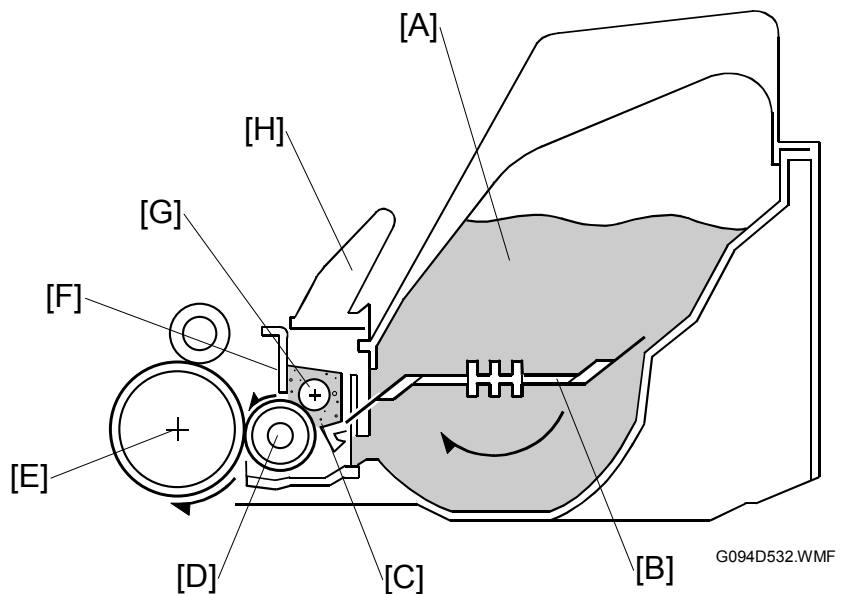

Toner Supply

The agitator [B] mixes toner and sends it to the development roller.

Development Unit

This machine uses a one-roller development system. The high voltage supply applies -700V to the development roller.

When the user removes the developer seal, the developer falls and the magnetic reverse roller [G] mixes the developer.

This machine does not use a TD sensor or ID sensor to control toner density. The pre-doctor blade [C] and the doctor blade [F] control the toner density.

Toner Density Control

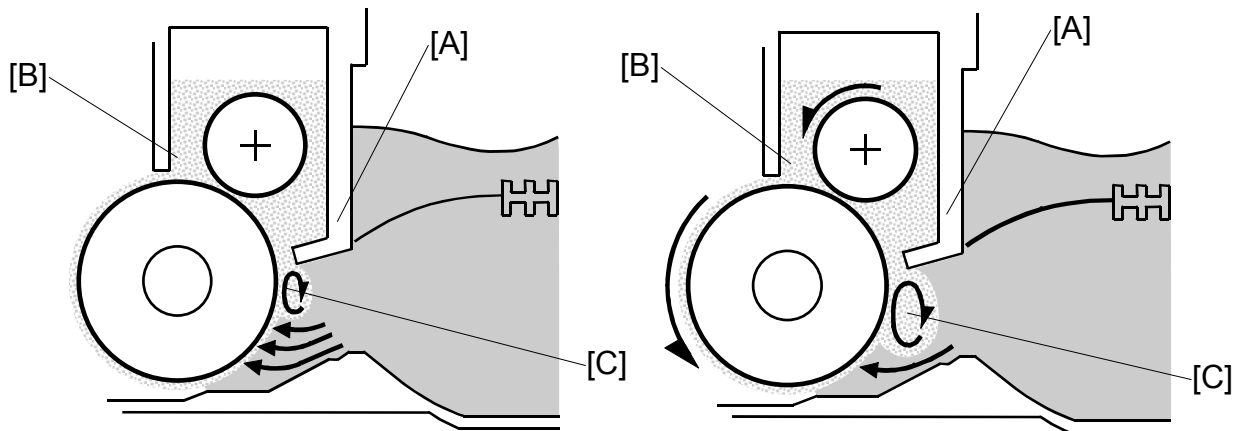

G094D533.WMF

G094D534.WMF

More toner is fed when the toner coating on the development roller

Less toner is fed when the toner coating on the development roller

- [A]: Pre-doctor blade
- [B]: Doctor blade
- [C]: Circulation of developer

A mixture of toner and developer circulates at the pre-doctor blade [A].

When the toner on the development roller decreases, the circulating region [C] gets smaller to let more toner get to the development roller.

When the toner on the development roller increases, the circulating region [C] gets bigger to let less toner get to the development roller.

Development Bias

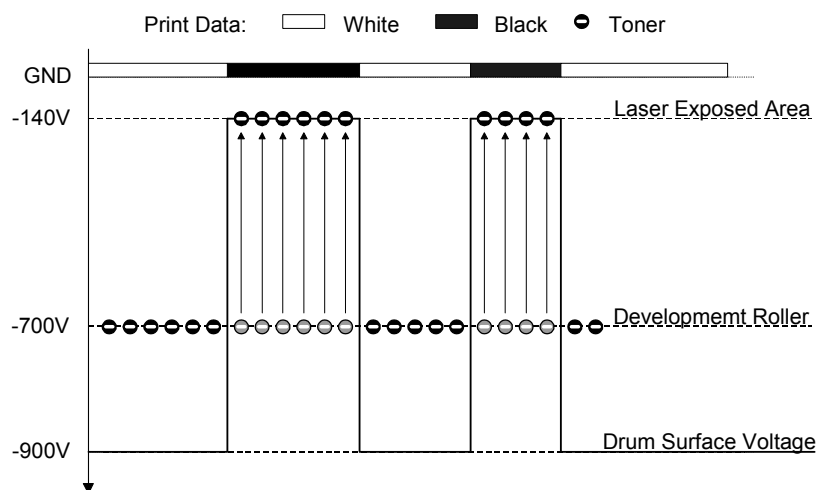

G094D535.WMF

Toner transfers from the development roller to the areas on the drum that were exposed to the laser.

Toner End Detection

[A]: Toner tank

[B]: Toner end sensor

The toner end sensor detects toner near-end by the voltage output.

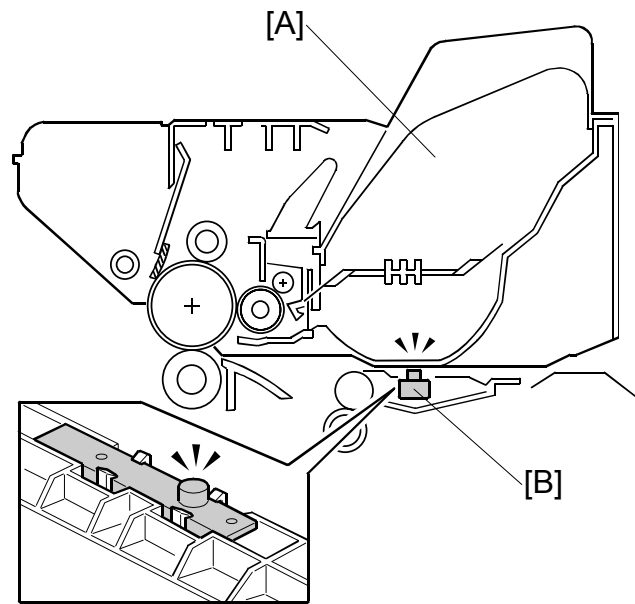

G094D536.WMF

Toner near-end

When the output from the toner end sensor is below a given level, the machine displays “Low on Toner” to tell the user.

Toner end

After toner near-end, the machine can print 200 more pages, and then it prevents printing. At this time, “Replace Toner Cartridge” is displayed. The 200-page limit can be changed with engine SP 2213.

The machine also displays “Replace Toner Cartridge” when the output from the toner end sensor is below a given level.

NOTE: To prevent waste toner tank overflow, you can make the machine stop printing if the total number of prints per cartridge is more than 30k. To make the machine stop, use engine SP 3923. To adjust the 30k limit, use engine SP 3922.

6.3.6 IMAGE TRANSFER AND PAPER SEPARATION

Overview

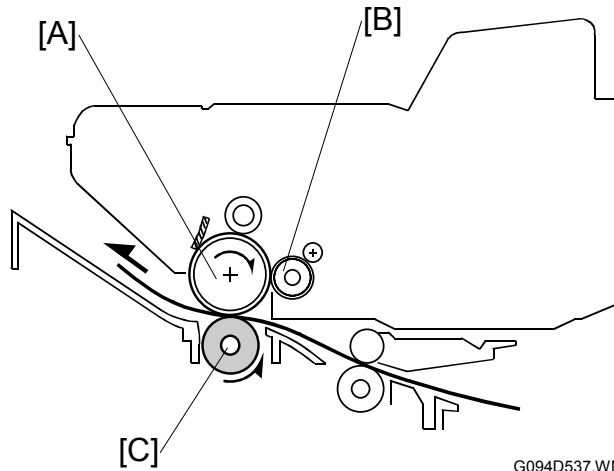

- [A]: Drum
- [B]: Development roller
- [C]: Transfer roller
- [D]: Transfer roller
- [E]: Separation plate
- [F]: High voltage supply

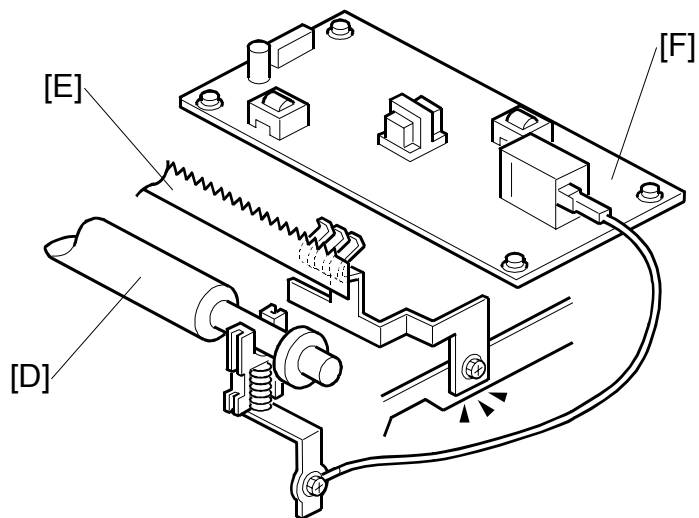

This machine uses a transfer roller [C] to pull the toner from the drum [A] to the paper. The high voltage supply [F] applies a positive current (+18 μ A) to the transfer roller [C]. To adjust the current applied to the transfer roller [C], use engine SP 2301. The separation plate [E] helps to remove paper from the drum.

Transfer Roller Cleaning

After a paper jam or when the user sets the incorrect paper size, toner can transfer to the rear side of printouts. To prevent this, the machine automatically cleans the transfer roller before the next printing cycle.

During transfer roller cleaning, the high voltage supply applies a negative current ($-3\mu\text{A}$) to the transfer roller.

The machine cleans the transfer roller in these conditions:

- At power on
- During fusing unit warm-up
- Immediately after a jam is removed
- When the front cover is opened and closed
- After a job which is 10 pages or larger

6.3.7 CLEANING

- [A]: Cleaning blade
 [B]: Drum
 [C]: Toner collection roller
 [D]: Waste toner tank

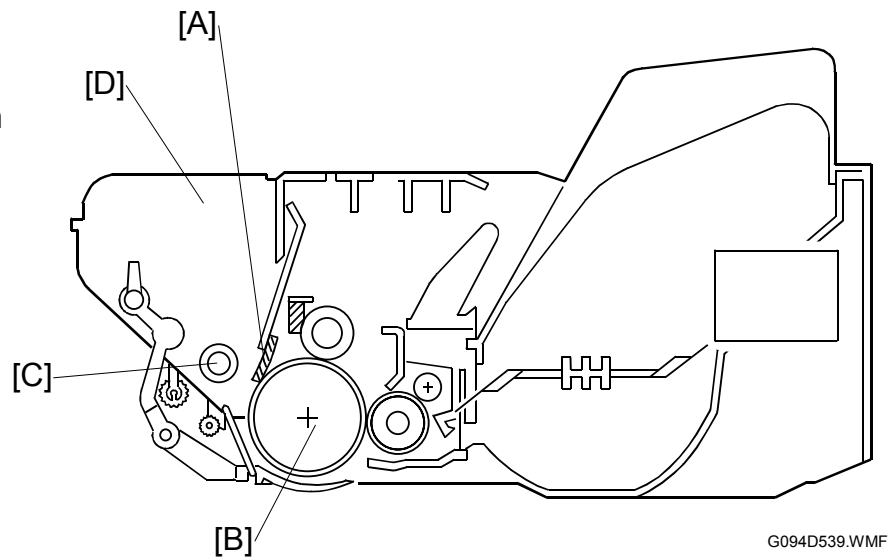

The cleaning blade [A] removes toner that remains on the drum. The toner collection roller [C] moves the toner to the waste toner tank.

There is no waste toner overflow detection. See “Toner End Detection” for more on how to prevent waste tank overflow.

6.3.8 QUENCHING

- [A]: Quenching lamp
- [B]: Drum

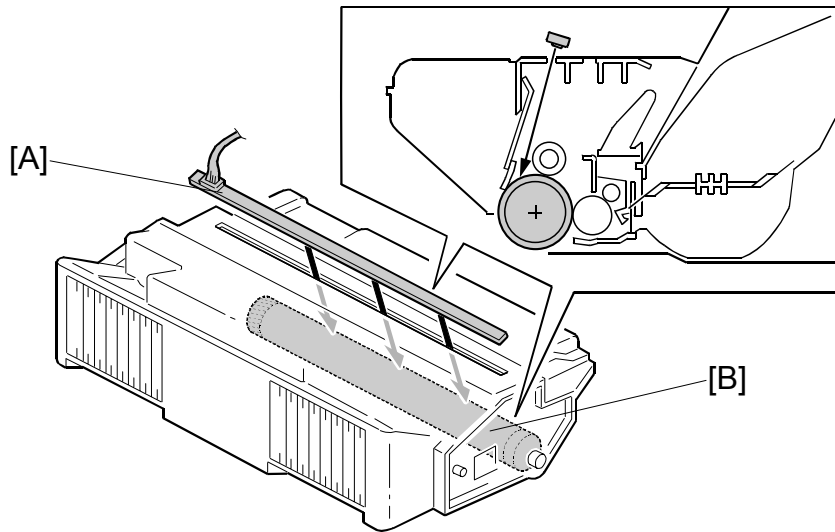

G094D540.WMF

Light from the quenching lamp [A] (LED) gets to the drum [B] through the opening at the top of the cartridge.

6.3.9 ID CHIP AND INTERNAL THERMISTOR

- [A]: ID chip
- [B]: Internal Thermistor
- [C]: Cartridge

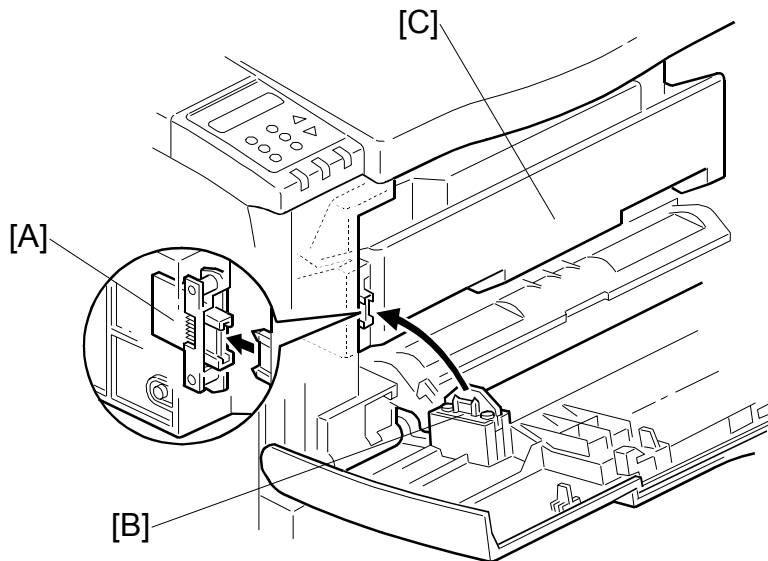

G094D541.WMF

The cartridge contains an ID chip.

6.4 PAPER FEED

6.4.1 OVERVIEW

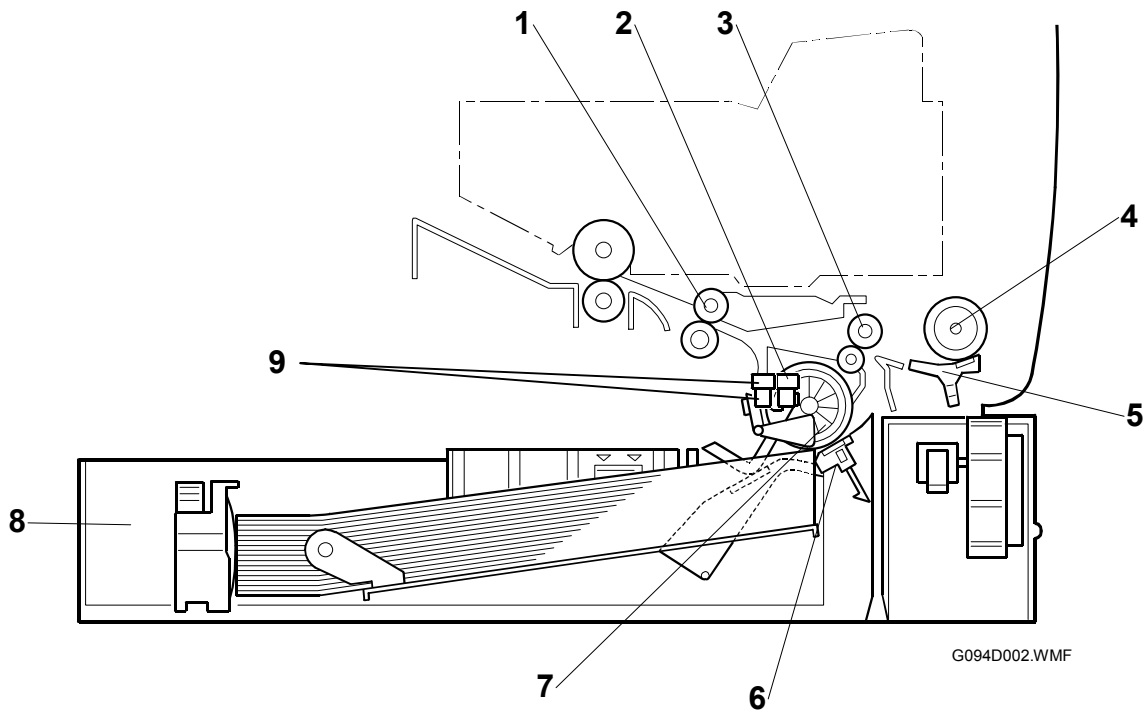

- | | |
|-------------------------|--------------------------------------|
| 1. Registration Roller | 5. Friction pad |
| 2. Relay Roller | 6. Feed roller |
| 3. By-pass feed roller | 7. Paper tray |
| 4. By-pass friction pad | 8. Paper end sensor |
| | 9. Remaining paper sensors (1 and 2) |

Detailed Descriptions

Paper Tray

Paper Feed System:	Feed roller and friction pad
Paper Lift Mechanism:	Tray arm and spring
Paper End Detection:	Remaining paper sensors Paper end sensor
Paper Size Detection:	Paper size switch
Tray Capacity:	500 sheets
Tray Extension:	Available

By-pass Tray

Paper Feed System:	Feed roller and friction pad
Paper Lift Mechanism:	Cams and springs
Paper Detection:	By-pass tray paper sensor
Paper Size Detection:	None
Tray Capacity:	100 sheets

6.4.2 PAPER TRAY

Tray Extension

The user can extend the tray manually to hold paper longer than A4/Letter size.

To use longer paper:

- Release the two locks [A]
- Then extend the tray and close the locks.

These paper sizes can be used:

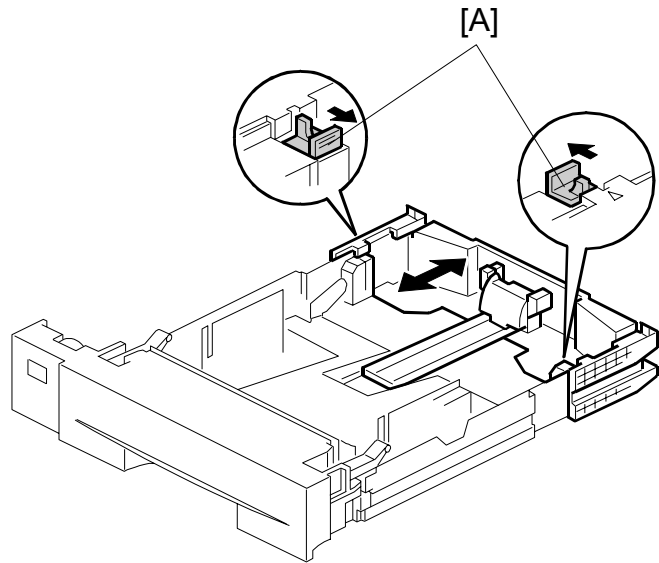

G094D003.WMF

Paper Sizes

Tray Mode	Possible Paper Sizes
Short (default)	A5 (LEF), B5 (LEF/SEF), A4 (LEF/SEF), 10.5"x7.25" (LEF), LT (LEF/SEF)
Long	B4 (SEF), A3 (SEF), 8.5"x13" (SEF), 8"x13" (SEF), 8.25"x13" (SEF), LG (SEF), DLT (SEF)

Paper Lift

When the user puts the tray [A] in the machine, the bottom plate [B] lifts as follows.

- The slopes on the guide blocks [C] on the machine lift the tray arms [D] up.
- The springs [E] between the tray arms and bottom plates lift the plate.
- The springs [E] keep the top sheet of the paper at the correct height.

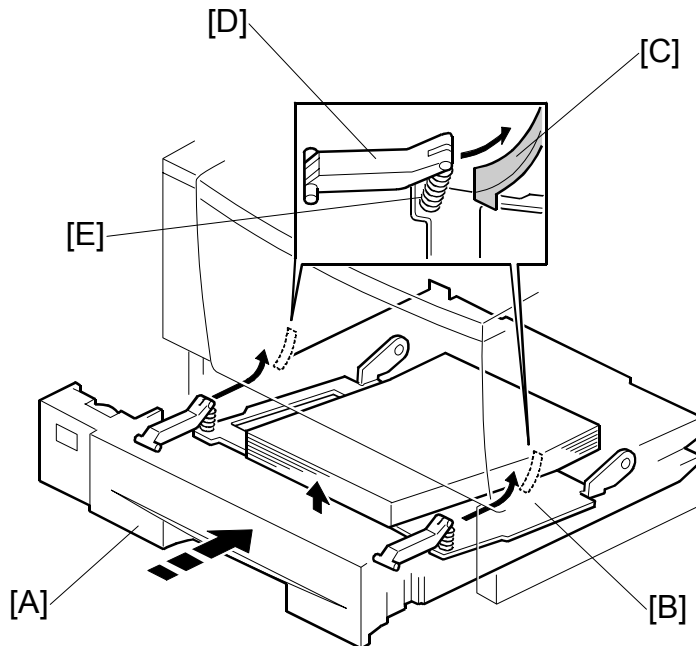

G094D004.WMF

Paper Feed and Registration

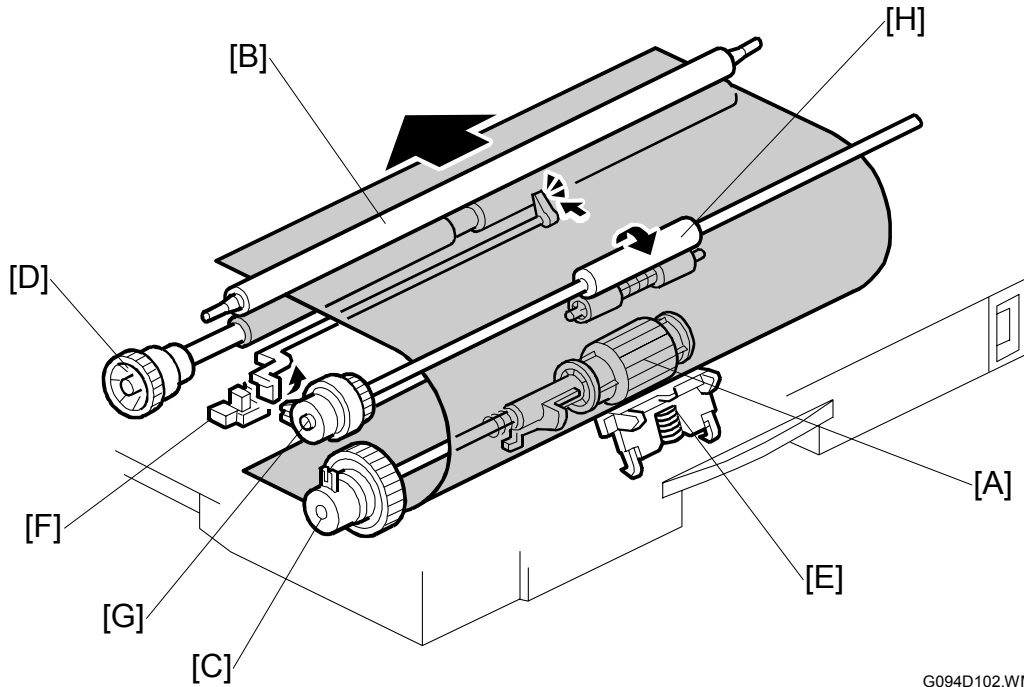

G094D102.WMF

- | | |
|--------------------------|--------------------------|
| [A]: Feed roller | [E]: Friction pad |
| [B]: Registration roller | [F]: Registration sensor |
| [C]: Paper feed clutch | [G]: Relay clutch |
| [D]: Registration clutch | [H]: Relay roller |

- NOTE:** 1) The friction pad cannot be adjusted.
 2) The machine makes a paper buckle at the registration roller to correct paper skew.
 3) The paper buckle can be adjusted with engine SP 1003.

Detailed
Descriptions

Paper Size Detection

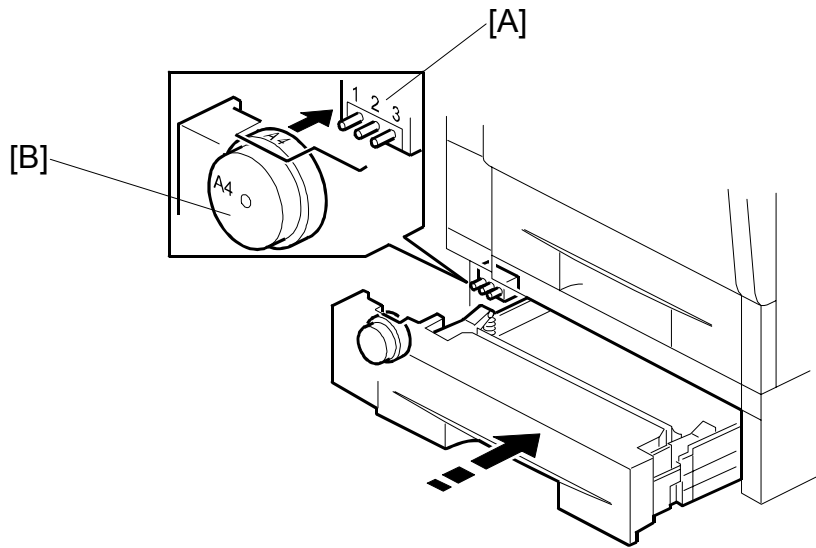

G094D542.WMF

[A]: Paper size switch
 [B]: Paper size dial

Paper Size Detection

Size \ SW	1	2	3
A3	○	○	○
A4 LEF	○	●	●
A4 SEF	○	○	●
A5 LEF	●	○	○
LT LEF	●	○	●
LT SEF	○	●	○
*	●	●	○

○: ON (Not pushed)
 ●: OFF (Pushed)

- The machine disables paper feed from a tray if it cannot detect the paper size. This occurs when the paper size actuator is broken or no tray is installed.
- When the dial is at the "*" mark, the user can set the paper tray up for a wider range of paper sizes with a User Tool (Paper Input menu – Tray Paper Size).

Paper End Detection

- When there is no paper in the tray, the feeler [A] falls into the cutout in the bottom plate, and the paper end sensor comes on.

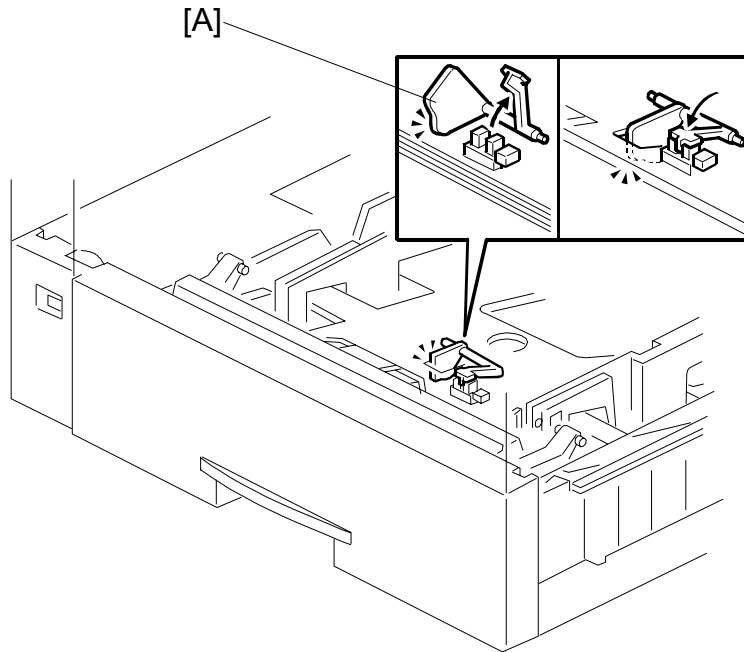

G094D543.WMF

Detailed
Descriptions

Remaining Paper Detection

- Remaining paper is detected by the combination of the remaining paper sensor signals. The signals from the sensors indicate whether there are 500, 450, 250, or 50 sheets remaining.

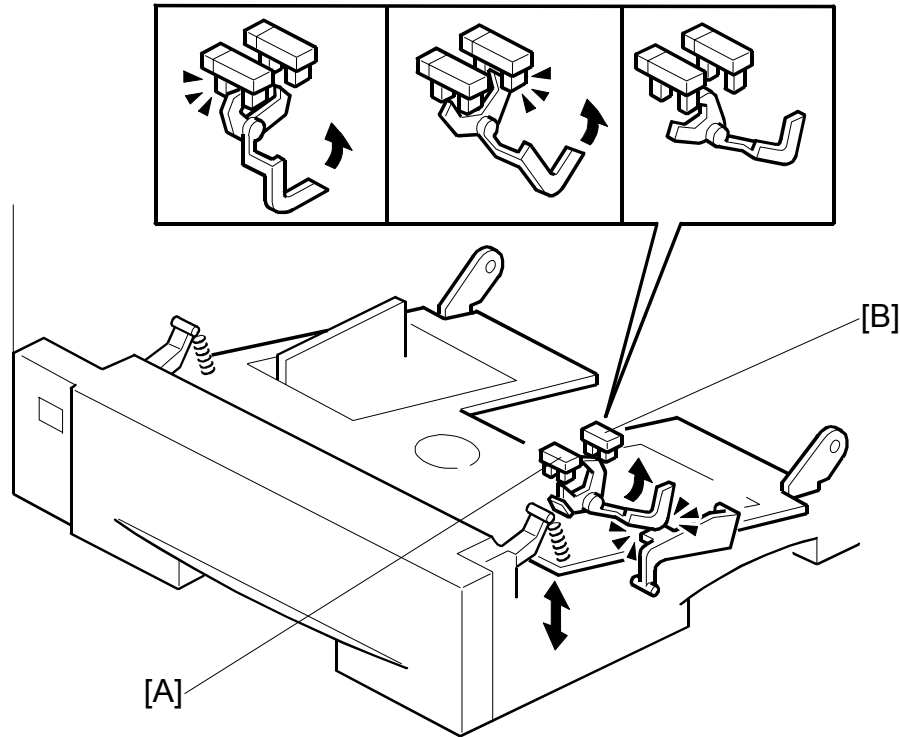

G091D111.WMF

- [A]: Remaining paper sensor 1
 [B]: Remaining paper sensor 2

Amount of paper	Remaining paper sensor 1	Remaining paper sensor 2
1-50 sheets (10%)	OFF	OFF
51-250 sheets (50%)	OFF	ON
251-450 sheets (90%)	ON	ON
451-500 sheets (100%)	ON	OFF

OFF: Unblocked, ON: Blocked

6.4.3 BY-PASS TRAY

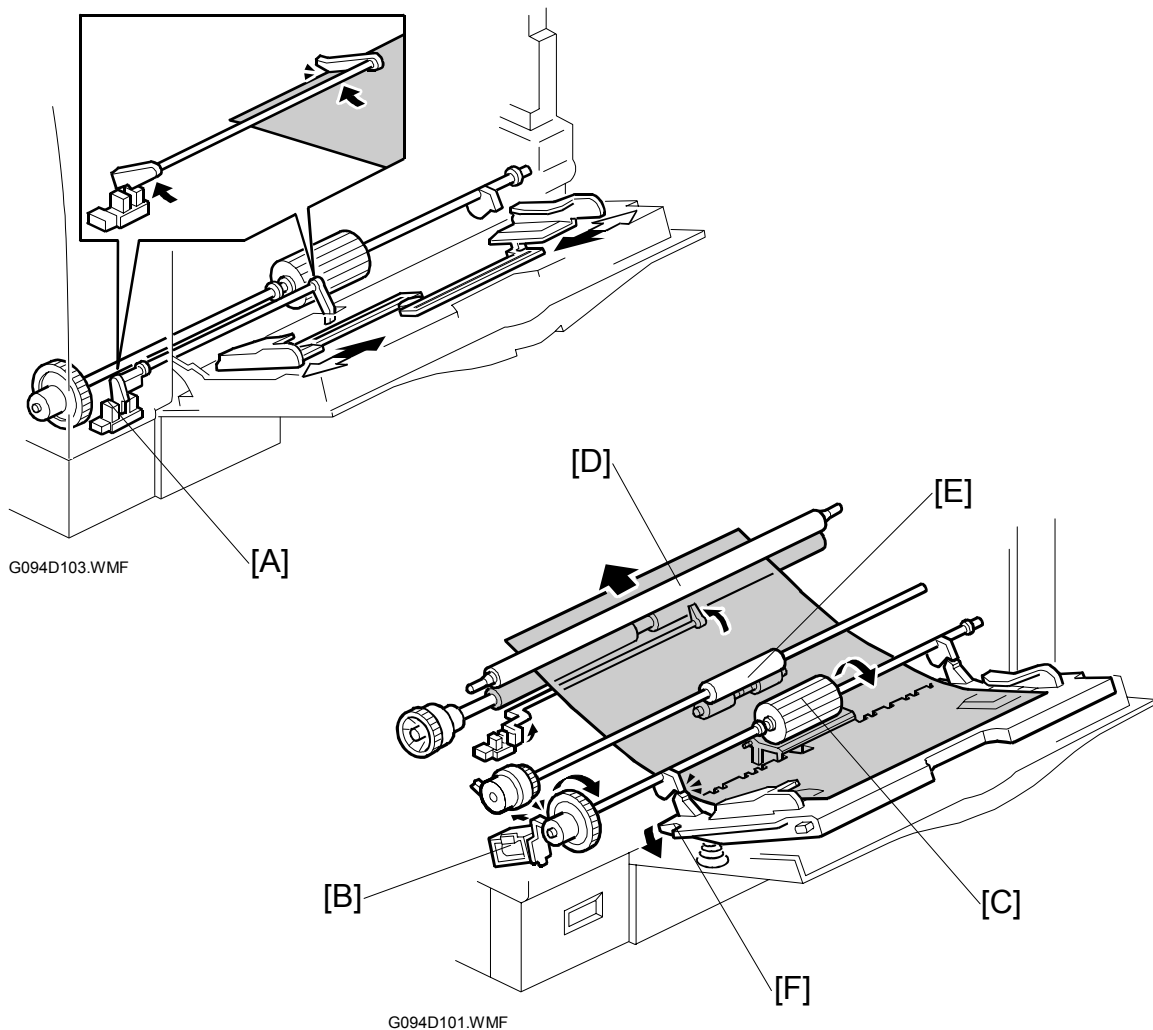

- The by-pass paper sensor [A] detects when paper is placed on the tray.
- The CPU energizes the by-pass feed solenoid [B]. Then the by-pass feed roller [C] starts to feed paper to the registration roller [D] through the relay roller [E].
- The by-pass feed roller shaft has two cams [F]. These cams release the bottom plate to press the stack of paper against the feed roller.
- There is no width sensor.

NOTE: To prevent bad effects from too much friction between the feed roller and friction pad, the feed roller contains a metal plate.

6.5 IMAGE FUSING AND PAPER EXIT

6.5.1 OVERVIEW

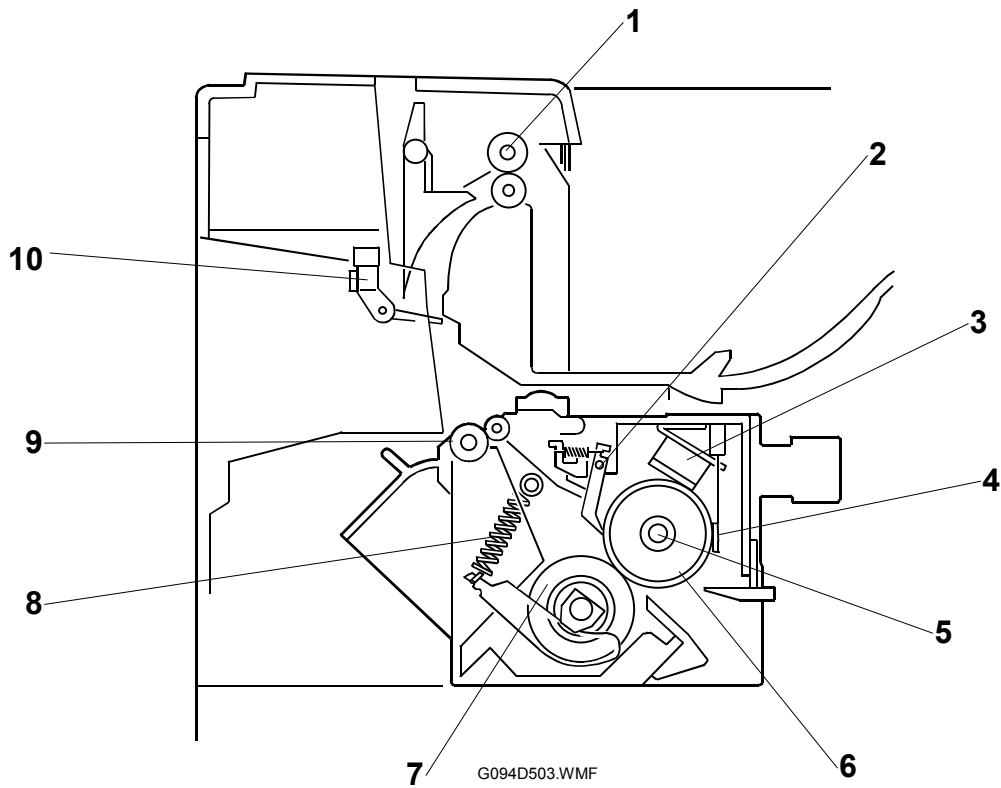

- | | |
|-------------------------|---------------------------|
| 1. Paper exit roller | 6. Hot roller |
| 2. Hot roller strippers | 7. Fusing pressure roller |
| 3. Thermostat | 8. Pressure spring |
| 4. Thermistor | 9. Fusing exit roller |
| 5. Fusing lamp | 10. Paper exit sensor |

6.5.2 FUSING DRIVE

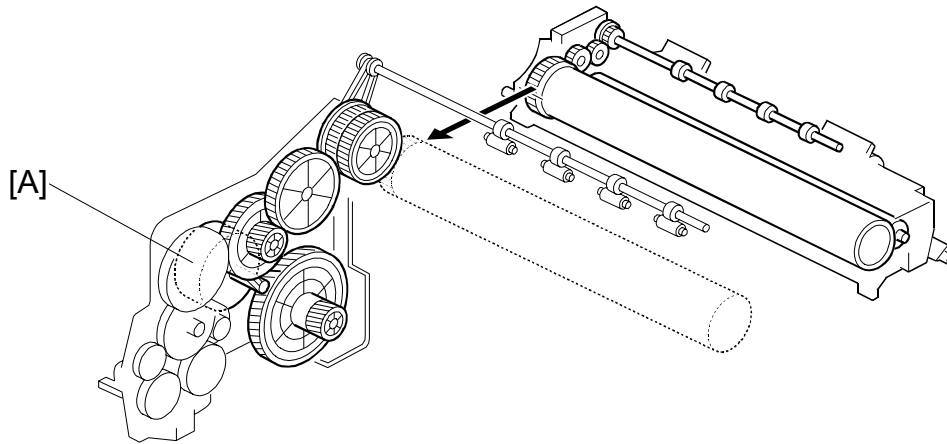

G094D504.WMF

The main motor [A] drives the fusing unit through a gear train.

6.5.3 FUSING ENTRANCE AND GUIDE SHAFT

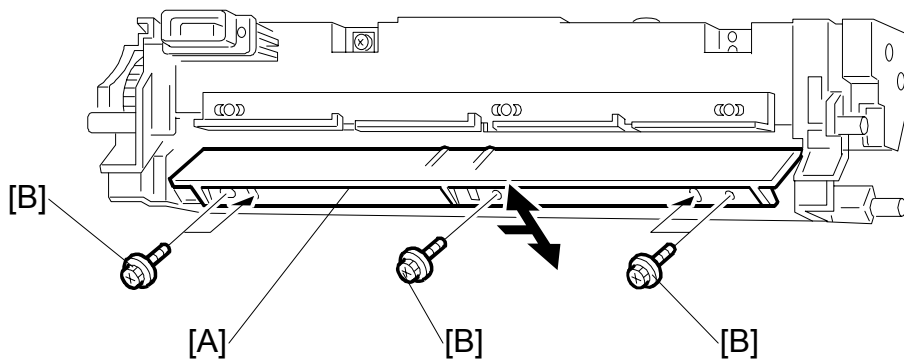

G094D545.WMF

Detailed
Descriptions

- NOTE:**
- 1) The entrance guide [A] is adjustable for paper thickness to prevent creasing.
 - 2) If creasing occurs frequently in the fusing unit, remove all screws [B] and slide the entrance guide to the right. Replace the two end screws only. Do not replace the middle screw.
 - 3) This procedure allows paper to have more direct access to the gap between the hot roller and the pressure roller.

6.5.4 PRESSURE ROLLER

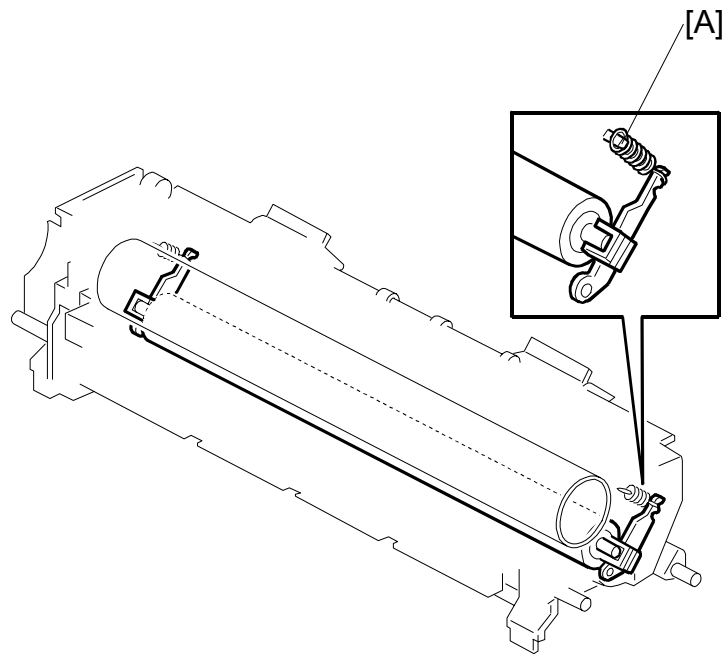

G094D505.WMF

- To change the applied pressure, adjust the position of the pressure springs [A]. The factory setting for the spring position is at the top (minimum pressure).

6.5.5 NEW FUSING UNIT DETECTION

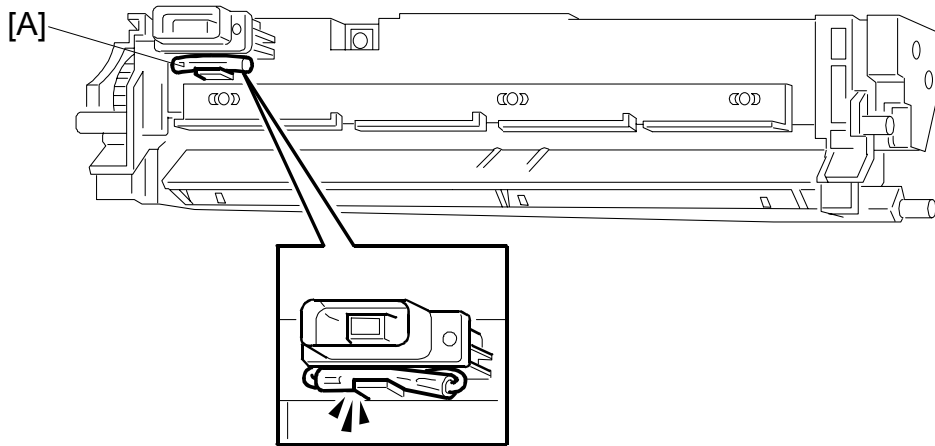

G094D546.WMF

There are two types of fusing unit: Service part, and Maintenance Kit part.

NOTE: Only the fusing unit in the maintenance kit has this detection mechanism.

In the maintenance kit fusing unit, the looped wire on the fusing unit connector contains a fuse [A]. When power is switched on after installing a new fusing unit, the engine board detects the fusing unit through the looped wire. However, the fuse opens very shortly afterwards.

What happens next depends on the setting of engine SP mode 5930 (Meter Charge):

If Meter Charge Mode is enabled

- After the technician replaces the fusing unit, the maintenance counter must be reset with engine SP mode 7-804.
 - 7-804-1: Transfer roller
 - 7-804-2: Paper feed roller
 - 7-804-3: Fusing unit).

If Meter Charge Mode is disabled (default setting)

- After the fusing unit has been replaced, the CPU detects the new unit and automatically removes the "Replace Maintenance Kit" message. Then, the maintenance counter resets automatically.

6.5.6 FUSING TEMPERATURE CONTROL

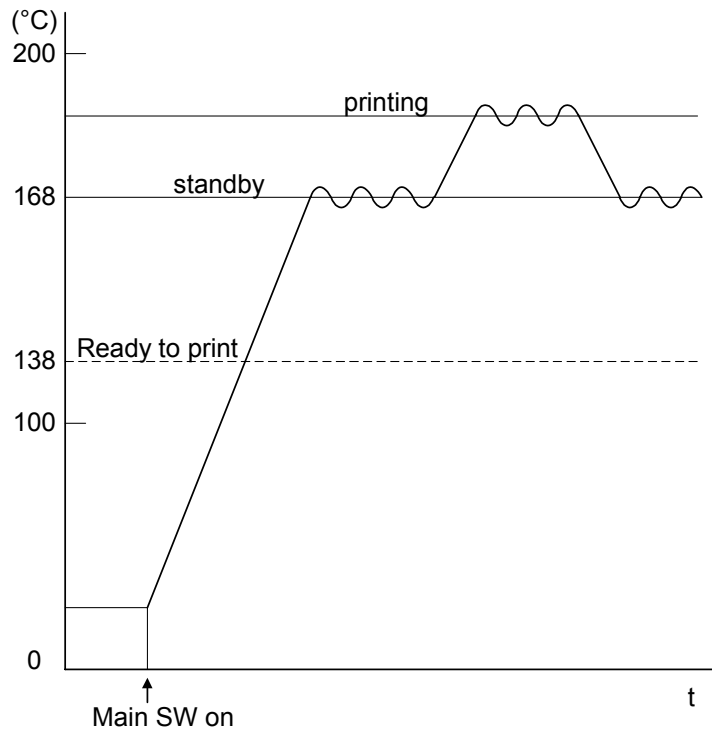

G094D547_CHN.WMF

When the main switch turns on, the CPU turns on the fusing lamp using the soft start process. The lamp stays on until the thermistor detects the standby temperature. Then the CPU maintains this temperature using on-off control. To start printing, the CPU raises the temperature to the printing temperature.

The fusing temperature for each mode is as follows:

Condition	Temperature			Note
Ready to print	138 °C			The machine can start to print any time.
Standby mode	168 °C			On-off control
Printing	Print start ~ 2 minutes	2 min. ~ 4 min.	4 min ~	On-off control
Tray	170 °C	165 °C	160 °C	
By-pass (Envelopes)	180 °C	180 °C	180 °C	
By-pass (Post Cards)	185 °C	185 °C	185 °C	
By-pass (Others)	170 °C	165 °C	160 °C	
Envelope Feeder	180 °C	180 °C	180 °C	
Thick Paper	185 °C	185 °C	185 °C	

NOTE: The soft start process prevents the room lights from flickering.

Overheat Protection

- If the hot roller temperature becomes greater than 240 °C, the CPU cuts off the power to the fusing lamp. At this time, SC543 will be generated.
- If the thermistor overheat protection fails, there is a thermostat in series with the common ground line of the fusing lamp. If the temperature of the thermostat becomes greater than 210 °C, the thermostat opens, removing power from the fusing lamp. At this time, the machine stops operation.

6.5.7 PAPER EXIT

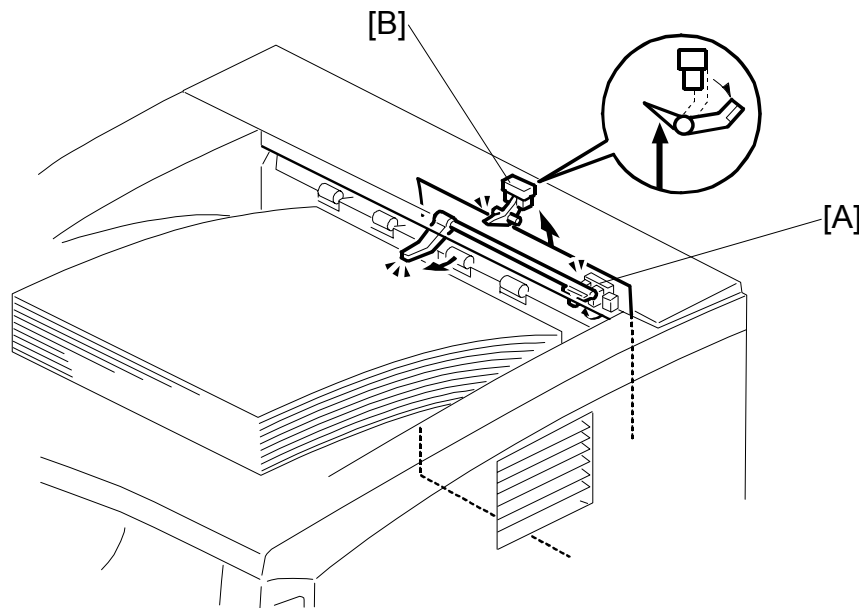

G094D601.WMF

[A]: Paper overflow detection sensor

[B]: Paper exit sensor

- When the paper overflow detection sensor [A] is activated, the machine detects that the paper stack height has exceeded a certain limit and stops printing.
- The paper exit sensor [B] detects paper misfeeds.

6.5.8 ENERGY SAVER MODE

When the machine is not being used, the energy saver feature reduces power consumption by switching off the fusing lamp.

Entering Energy Saver Mode

Energy saver mode starts after the machine has been idle for a certain time. The user specifies the time and the following choices are available:

NOTE: Press the Menu key on the operation panel, and access the System menu).

- Off (energy saver mode never activates)
- 5 minutes
- 15 minutes
- 30 minutes (default)
- 60 minutes

When the machine is in energy saver mode, the CPU turns off the fusing lamp. However, the +24V, +12V, and +5V lines are still active.

Leaving Energy Saver Mode

The machine leaves energy saver mode when one of the following happens.

- Print command received from the PC
- Any cover opened and closed
- Any operation panel keys pressed

6.6 CONTROLLER FUNCTIONS

6.6.1 METER CHARGE MODE

Meter-charge Counter Display

When meter charge mode (engine SP 5930) is switched on, the meter-charge counter menu is the first item shown on the user menu.

(The “Sample Print” menu appears first when the meter-charge mode is switched off.)

Menu: Counter

PM Warning Display

When meter charge mode (engine SP 5930) is switched on, “Replace Maintenance Kit” will not be displayed at 90k prints.

NOTE: The default setting for this machine is meter-charge mode off.

Item	Meter-charge On	Meter-charge Off	Remarks
Meter-charge counter	Shown as the first item in the user menu	Not shown	User menu
PM Warning	Not shown	“Replace Maintenance Kit” displayed at 90k prints	
PM	Service	Customer	
PM Counter	Reset manually	Automatically reset when the fusing unit is replaced using the maintenance kit	Printer engine service mode “PM counter”

The meter-charge counter is not the same as the PM counter. This is because, in the following cases, the meter-charge counter does not count up.

- Blank rear side during duplex printing
- Blank page when using the “Cover Page” or “Two in One” features
- Service reports

NOTE: The meter-charge counter cannot be reset.

SPECIFICATIONS

1. GENERAL SPECIFICATIONS

The specifications in this section are for the G091 China model machine.

Configuration	Desktop	
Paper size	A3 / 11"x17" SEF – A6 SEF	
Technology	Laser beam scanning & Electro photographic printing Dual component toner development AIO is used	
Print Resolution	300 dpi, 600 dpi, 1200 dpi	
Smoothing	Yes (on, off)	
Continuous Print Speed	32 ppm (A4/LT LEF)	
Duplex Print Speed	31.5 ppm from standard tray	
	27 ppm from first optional paper tray	
	23 ppm from second optional paper tray	
First Print Speed	6.5 seconds or less (A4/LT, LEF from standard tray)	
Copy Paper Weight	Paper Tray	60-105 g/m ² (16-28 lb.)
	By-pass tray	52-162 g/m ² (14-43 lb.)
	Optional paper tray	60-105 g/m ² (16-28 lb.)
	Duplex	64-105 g/m ² (17-28 lb.)
Warm-up Time	19 seconds or less from power on (23 °C, 73 °F)	
	12 seconds or less from energy saver mode	
Paper Input Size	Standard tray	A3 / 11" x 17" – A5 LEF
	By-pass tray	A3 / 11" x 17" – A6 SEF
	By-pass tray-Custom size paper	Length: 148 - 432 mm Width: 90 - 305 mm Com#10, C5, C6, DL. Monarch
	Optional Envelope Feeder	Com#10, C5, C6, DL. Monarch
	Optional paper tray unit Up to 2 units can be installed.	A3 / 11" x 17" – B5 LEF
Paper Input Capacity	Standard tray and Optional paper trays	500 sheets (80 g/m ² , 20 lb.)
	By-pass tray	100 sheets (80 g/m ² , 20 lb.)
	Optional Envelope feeder	60 envelopes
Output Capacity	250 sheets (Maximum 500 sheets)	
Total Counter	Electric Counter	
Environmental Standard	CCC Regulation	

2. PHYSICAL SPECIFICATIONS

Power Source	220 V - 240 V, 50/60 Hz: More than 6.0 A		
Power Consumption		Main Unit (including NIB)	Full system
	Maximum	850 W or less	920 W or less
	Printing	620 W or less	650 W or less
	Energy Saver	6.5 W or less	10.5 W or less
Noise Emission		Mainframe Only	Full System
	Printing	67 dB or less	71 dB or less
	Stand-by	40 dB or less	40 dB or less
	Energy Saver	40 dB or less	40 dB or less
Sound Pressure Level	Printing	55dB or less (Operating position)	
	Energy Saver	30dB or less (Operating position)	
Weight	19.5 Kg. 43 lb. (including Paper Tray and AIO)		
Dimensions (W x D x H)	Excluding standard tray	478 x 410 x 343 mm	
	Including standard try	478 x 437/575 x 343 mm	

3. CONTROLLER

CPU	TX4955 300Mhz	
Printer Languages	RPCS, PCL6, PCL5e emulation, Adobe PS3 (genuine), Adobe PDF	
Resolution	RPCS	600/1200 dpi
	PCL6	600/1200 dpi
	PCL5e	300/600 dpi
	PS3	600/1200 dpi
Resident Fonts	PCL	35 Intellifonts, 10 TrueType fonts, 1 bitmap font
	PS	136 Type1 fonts
	Font Manager and 31 additional fonts for PCL to be loaded to the PC, Euro currency ok.	
Drivers	RPCS	Win95/98/Me, Win NT 4.0, 2000, XP, Server 2003
	PCL6	Win95/98/Me, Win NT 4.0, 2000, XP, Server 2003
	PCL5e	Win95/98/Me, Win NT 4.0, 2000, XP, Server 2003
	PS3	Win95/98/Me, Win NT 4.0, 2000, XP, Server 2003
	Mac OS 8.6.0 or later, Mac OSX (10.1 or later)	
ROM	Flash: 16 MB (Emulation) Mask: 4MB (PCL/PS font)	
RAM	Resident	64 MB SDRAM
	Option	1 slot SDRAM DIMM (64/128/256 MB)
HDD	Option: Approximately 6 GB	
Interface	Standard	USB2.0 (Win98, 2000, ME, XP, Server 2003)
		Bi-directional IEEE1284 10/100 Base-TX
Firmware Update	Flash Memory card (3 cards)	
	RFU (Remote Firmware Update)	
Network Protocol	TCP/IP (including IPP), IPX/SPX, NetBEUI, Apple Talk	
NRS	Supported	

4. SUPPORTED PAPER SIZES

Paper	Size (W x L)	Paper Trays Main Unit/Option		By-pass Tray	Env. Feeder	Duplex
		US	Eur/Asia			
A3	297 x 420 mm	Y [#] /Y	Y/Y	Y [#]	N	Y
B4	257 x 364 mm	Y [#] /Y [#]	Y [#] /Y [#]	Y [#]	N	Y
A4 SEF	210 x 297 mm	Y [#] /Y	Y/Y	Y [#]	N	Y
A4 LEF	297 x 210 mm	Y/Y	Y/Y	Y [#]	Y	Y
B5 SEF	182 x 257 mm	Y [#] /Y [#]	Y [#] /Y [#]	Y [#]	N	Y
B5 LEF	257 x 182 mm	Y [#] /Y [#]	Y [#] /Y [#]	Y [#]	N	Y
A5 SEF	148 x 210 mm	N	N	Y [#]	N	N
A5 LEF	210 x 148 mm	Y [#] /N	Y/N	Y [#]	N	Y
A6 SEF	105 x 148 mm	N	N	Y ^C	N	N
Ledger	11" x 17"	Y/Y	Y [#] /Y	Y [#]	N	Y
Legal	8.5" x 14"	Y/Y	Y [#] /Y	Y [#]	N	Y
Letter SEF	8.5" x 11"	Y/Y	Y/Y	Y [#]	N	Y
Letter LEF	11" x 8.5"	Y/Y	Y/Y	Y [#]	N	Y
Half Letter SEF	5.5" x 8.5"	N	N	Y [#]	N	N
Half Letter LEF	8.5" x 5.5"	N	N	N	N	N
Executive SEF	7.25" x 10.5"	N/Y [#]	N/Y [#]	Y [#]	N	N
Executive LEF	10.5" x 7.25"	Y [#] /Y [#]	Y [#] /Y [#]	Y [#]	N	Y
F	8" x 13"	Y [#] /Y [#]	Y [#] /Y [#]	Y [#]	N	Y
Foolscap	8.5" x 13"	Y/Y [#]	Y [#] /Y [#]	Y [#]	N	Y
Folio	8.25" x 13"	Y [#] /Y [#]	Y [#] /Y [#]	Y [#]	N	Y
Com10 Env.	4.125" x 9.5"	N	N	Y [#]	Y [#]	N
Monarch Env.	3.875" x 7.5"	N	N	Y [#]	Y [#]	N
C6 Env.	114 x 162 mm	N	N	Y [#]	Y [#]	N
C5 Env.	162 x 229 mm	N	N	Y [#]	Y [#]	N
DL Env.	110 x 220 mm	N	N	Y [#]	Y [#]	N
8K	267 x 390 mm	Y [#] /Y [#]	Y [#] /Y [#]	Y [#]	N	Y
16K SEF	195 x 267 mm	Y [#] /Y [#]	Y [#] /Y [#]	Y [#]	N	Y
16K LEF	267 x 195 mm	Y [#] /Y [#]	Y [#] /Y [#]	Y [#]	N	Y
Custom	Minimum: 90 x 148 mm Maximum: 305 x 432 mm	N/Y ^C	N/Y ^C	Y ^C	N	N

Y: Supported. The paper size sensor detects the paper size.

Y[#]: Supported. The user has to select the correct paper size for the tray.

Y^C: Supported. The user has to enter the width and length of the paper.

N: Not supported.

5. OPERATION PANEL LED SPECIFICATIONS

LED	Color	Appearance	Meaning
Power	Green	Off	Power off or in Energy Saver mode
		Flashing	Warming up
		On	Power on and not in Energy Saver mode
Data In	Green	Off	No data
		Flashing	Data being received or processed or the printer is spooling
		On	Data being received or processed; more data coming
Online	Green	Off	Printer off-line
		Flashing	Going off-line
		On	Ready to print
Error	Red	Off	No messages or error conditions requiring attention
		On	Printer requires service

6. EXTERNAL OPTIONS

Paper Feed Unit (G555)	Paper Size	A3/ 11" x 17"-B5 LEF
	Paper Weight	60 – 105g/m ² , 16 – 28 lb.
	Paper Capacity	Maximum 500 sheets
	Dimensions (W x D x H)	468 x 410/545 x 130 mm
	Weight	6 kg
Duplex Unit (G552)	Paper Size	A3/ 11" x 17"-A5 LEF
	Paper Weight	64 – 105g/m ² , 18 – 28 lb.
	Dimensions (W x D x H)	419 x 378 x 257 mm
	Weight	6 kg
4-Bin Mailbox (G553)	Paper Size	A3/ 11" x 17"-A5 LEF
	Paper Stack	50 sheets / bin (80g/m ²)
	Paper Weight	60 – 105g/m ² , 16 – 28 lb.
	Dimensions (W x D x H)	465 x 395 x 285 mm
	Weight	5.5 kg
1-Bin Shift Tray (G554)	Paper Size	A3/ 11" x 17"-A5 LEF
	Paper Stack	250 sheets / bin (80g/m ²)
	Paper Weight	60 – 105g/m ² , 16 – 28 lb.
	Dimensions (W x D x H)	465 x 395 x 160 mm
	Weight	3.5 kg.

Spec.

7. SOFTWARE ACCESSORIES

The printer drivers and utility software are provided on one CD-ROM. An auto-run installer allows you to select which components to install.

7.1 PRINTER DRIVERS

Printer Language	Windows 95/98/ME	Windows NT4.0	Windows 2000	Windows XP	Server 2003	Macintosh
PCL 6	Yes	Yes	Yes	Yes	Yes	No
PCL 5e	Yes	Yes	Yes	Yes	Yes	No
PS3	Yes	Yes	Yes	Yes	Yes	Yes
RPCS	Yes	Yes	Yes	Yes	Yes	No

- NOTE:** 1) The printer drivers for Windows NT 4.0 are only for the Intel x86 platform. There is no Windows NT 4.0 printer driver for the PowerPC, Alpha, or MIPS platforms.
- 2) The PS3 drivers are all genuine AdobePS drivers, except for Windows 2000, which uses Microsoft PS. A PPD file for each operating system is provided with the driver.
- 3) The PS3 driver for Macintosh supports Mac OS 7.6 or later versions.

7.2 CD-ROM CONTENTS

Utilities and Drivers CD-ROM

Environment	Contents	Language	Remarks
Windows	RPCS Driver	English, Simplified Chinese	Windows 95/98/Me, NT4.0, 2000, XP, Server 2003
	PCL6 Driver	English, Simplified Chinese	Windows 95/98/Me, NT4.0, 2000, XP, Server 2003
	PCL5e Driver	English, Simplified Chinese	Windows 95/98/Me, NT4.0, 2000, XP, Server 2003
	Adobe PS3 Printer Driver	English only	Windows 95/98/Me, NT4.0, 2000, XP, Server 2003
	Font Manager 2000	English only	Windows 95/98/Me, NT4.0, 2000, XP, Server 2003
	SmartNetMonitor (Client)	English, Simplified Chinese	Windows 95/98/Me, NT4.0, 2000, XP, Server 2003
	SmartNetMonitor (Admin)	English, Simplified Chinese	Windows 95/98/Me, NT4.0, 2000, XP, Server 2003
	1394 UTILITY	English only	Windows 2000, XP, Server 2003
	README.TXT	English only	—
Macintosh	Adobe PS3 Printer Driver	English only	Mac OS 8 and 9
	PS Descriptions	English only	Mac OS 8 and 9
	Printer Utility for Mac	English only	Mac OS 8 and 9, Mac OS X

Operating Instructions CD-ROM

Environment	Contents	Language	Remarks
Windows/ Macintosh	Setup Guide	English, Simplified Chinese	
	Printer Reference	English, Simplified Chinese	
	NIC Operating Instructions	English, Simplified Chinese	
	PS Supplement	English, Simplified Chinese	
	Adobe Acrobat Reader	English, Simplified Chinese	

8. MACHINE CONFIGURATION

8.1 SYSTEM COMPONENTS

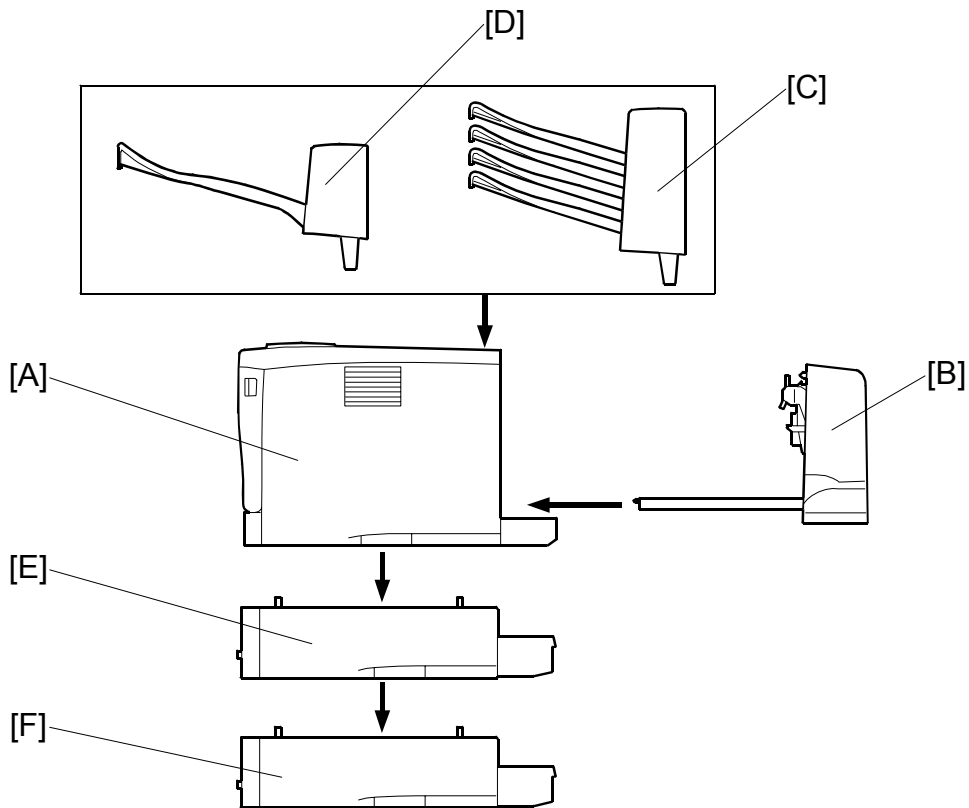

G091V107.WMF

Item	Machine Code	No.	Remarks
Main Unit	G091	A	The NIB is standard for this model.
Optional Units			
Duplex Unit	G552	B	Also used with model K-P2
Paper Tray Unit	G555	E, F	Up to two tray units can be installed.
Four-Bin Mailbox	G553	C	Also used with model K-P2
One-Bin Shift Tray	G554	D	Also used with model K-P2

8.2 INTERNAL OPTIONS

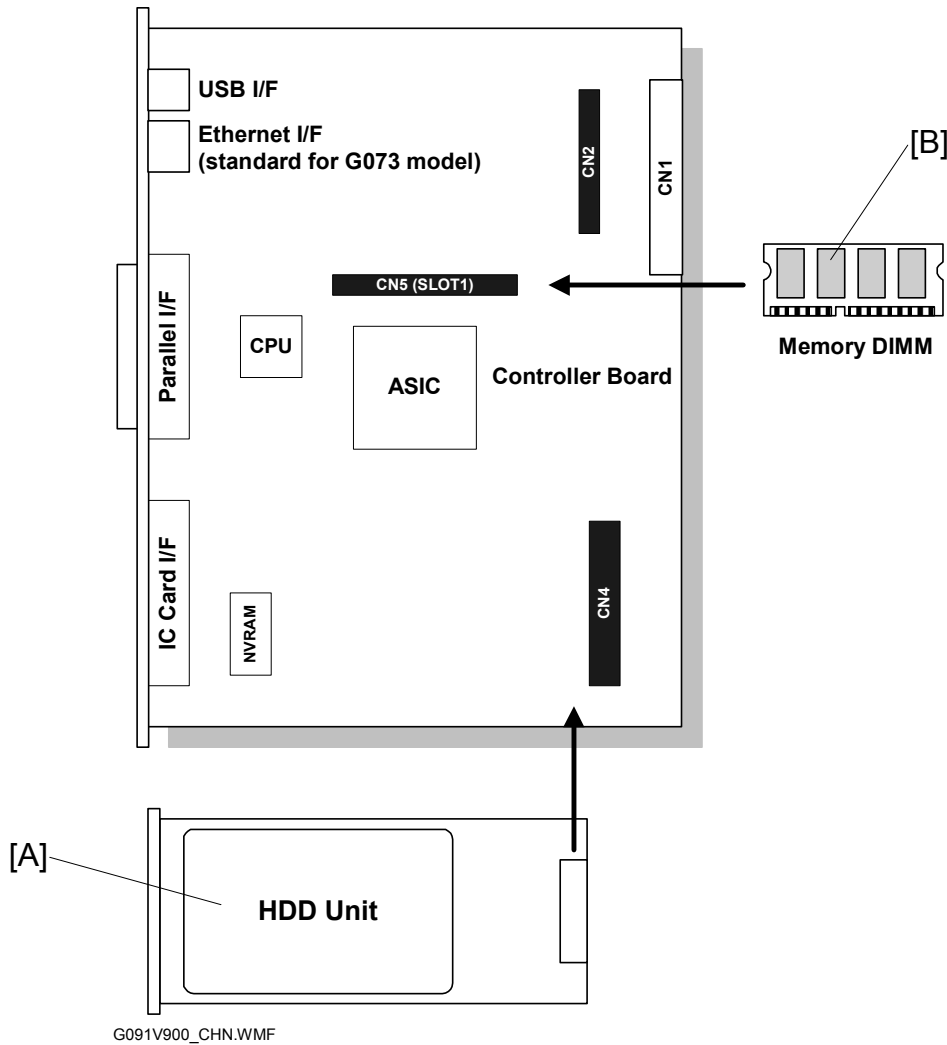

Internal Options			
HDD	G575	A	Also used with model K-P1
Memory 64/128/256 MB	G330/G331/ G332	B	Also used with model K-P1
Barcode Font DIMM	G627		Also used with model K-P1
Others			
AIO Cartridge	G213/G775		Also used with model K-P1
Maintenance Kit	G770		

NOTE: This model has an on-board Ethernet interface.

Spec.